

# HN System

## Installation Manual for .98 m Ku-band Upgradeable Antenna Model AN6-098P

1037312-0001  
Revision A  
March 2, 2007

### **Copyright © 2007 Hughes Network Systems, LLC**

All rights reserved. This publication and its contents are proprietary to Hughes Network Systems, LLC. No part of this publication may be reproduced in any form or by any means without the written permission of Hughes Network Systems, LLC, 11717 Exploration Lane, Germantown, Maryland 20876.

Hughes Network Systems, LLC has made every effort to ensure the correctness and completeness of the material in this document. Hughes Network Systems, LLC shall not be liable for errors contained herein. The information in this document is subject to change without notice. Hughes Network Systems, LLC makes no warranty of any kind with regard to this material, including, but not limited to, the implied warranties of merchantability and fitness for a particular purpose.

### **Trademarks**

Hughes, Hughes Network Systems, and HughesNet are trademarks of Hughes Network Systems, LLC. All other trademarks are the property of their respective owners.

# Important safety information

---

For your safety and protection, read this entire installation manual before you attempt to install the satellite antenna. In particular, read this safety section carefully. Keep this safety information where you can refer to it if necessary.

---

## Types of warnings used in this manual

This section introduces the various types of warnings used in this manual to alert you to possible safety hazards.

---

### **DANGER**



Indicates an imminently hazardous situation, which, if not avoided, will result in death or serious injury.

---

### **WARNING**



Indicates a potentially hazardous situation, which, if not avoided, could result in death or serious injury.

---

### **CAUTION**



Indicates a potentially hazardous situation, which, if not avoided, may result in minor or moderate injury.

---

### **CAUTION**

Indicates a situation or practice that might result in property damage.

---

## Product warning labels

The following safety alert labels are affixed to the satellite antenna feed support tube, transmitter, and antenna reflector:



Feed support tube



Transmitter



Reflector (back side)

### Safety alert labels on the antenna assembly

These labels advise that the antenna emits radio frequency (RF) energy. Because of this potential safety hazard, observe all cautions on these labels and in the following section (*Antenna installation safety*) concerning RF radiation.

---

## Antenna installation safety

Observe the following precautions when installing the satellite antenna. This manual also includes additional safety alerts where appropriate concerning specific installation procedures.



---

### **WARNING**

**Only Hughes-certified installers may install or service Hughes earth stations and components. Installers must expressly acknowledge the Hughes requirements for Hughes installations.**

---



---

### **DANGER**

**If you work on a roof, tower, or other high structure or use a ladder or scaffold to access the work site, follow these precautions to prevent personal injury or death:**

- Walk only on sound roof structures.
  - Make sure the antenna assembly and installation surface are structurally sound so they can support all loads (equipment weight, ice, and wind).
  - Use appropriate safety equipment (for example, a lifeline), depending on the work location.
  - Follow all safety precautions from the manufacturers of all safety equipment and other equipment used.
  - Perform as many procedures as possible on the ground.
- 



---

### **DANGER**

- To avoid electric shock, stay at least 20 ft from power lines.
- If any part of the antenna or mount assembly comes in contact with a power line, call your local power company to remove it. *Do not try to remove it yourself.*

**Failure to heed these warnings could result in serious injury or death.**

---



---

 **WARNING**

- Do not work in high wind or rain or if a storm, lightning, or other adverse weather conditions are present or approaching.
  - Do not attempt to assemble, move, or mount the antenna on a windy day. Even a slight wind can unexpectedly create strong, unexpected forces on the antenna surface.
-

---

## CAUTION

Observe these precautions to avoid exposure to RF radiation, a potential safety hazard:

- The antenna must be installed in a location or manner not readily accessible to children and in a manner that prevents human exposure to potentially harmful levels of radiation.
- Antennas mounted in Puerto Rico, the continental United States, or at any site with greater than a 30° elevation angle must be installed such that the lower lip of the antenna reflector is at least 5 ft above any surface upon which a person might be expected to stand, and 3 ft 3 inches from any opening (such as a door or window) in a building or adjacent structure.
- Antennas mounted in Canada, Alaska, Hawaii, or any site with less than a 30° elevation must be installed such that the lower lip of the antenna reflector is at least 5 ft 9 inches above any surface upon which a person might be expected to stand, and 3 ft 3 inches from any opening (such as a door or window) in a building or adjacent structure.
- The antenna must be mounted such that no object which could reasonably be expected to support a person is within 6 ft 7 inches of the edges of a cylindrical space projecting outward from the antenna reflector toward the satellite.
- If the above distance requirements cannot be met, the antenna must be mounted in a controlled area inaccessible to the general public, such as a fenced enclosure or a roof.
- The antenna must be mounted such that there is no object outside the controlled area which could reasonably be expected to support a person within 6 ft 7 inches of the edges of a cylindrical space projecting outward from the antenna reflector toward the satellite.
- A fenced installation must have a locked entry, and the fenced area must be large enough to protect the general public from exposure to potentially harmful levels of radiation.
- Access to a roof installation in a commercial, industrial, or institutional environment must be limited by a door or a permanently fastened ladder that is locked to deny access to the general public.



Failure to observe these cautions could result in injury to eyes or other personal injury.

---

---

 **CAUTION**



- All installations of any type or size must carry an industry standard and government approved *Radiation Hazard Caution* label on the feed arm.
- A fenced or roof installation in a commercial, industrial, or institutional environment must carry a *Radiation Hazard Caution* sign on the access door, gate, or permanently mounted access ladder that is within plain sight of anyone approaching the antenna from the front or sides of the reflector.

**Failure to observe these cautions could result in injury to eyes or other personal injury.**

---

Some installations may require additional precautions. See also the HN System *Antenna Site Preparation and Mount Installation Guide* (1035678-0001).



# Contents

---

- Important safety information . . . . . iii**
- Types of warnings used in this manual . . . . . iii
- Product warning labels . . . . . iv
- Antenna installation safety . . . . . v
- About this document . . . . . xvii**
- Scope and audience . . . . . xvii
- Organization . . . . . xvii
- Related publications . . . . . xviii
- Revision record. . . . . xviii
  
- Chapter 1**
- Overview . . . . . 1**
- The model AN6-098P antenna . . . . . 2
- Antenna installation summary . . . . . 3
- Tasks related to antenna installation . . . . . 4
  - Selecting the installation site . . . . . 4
  - Installing the antenna mount . . . . . 4
  - Installing the IDU . . . . . 4
  - Grounding. . . . . 4
  - Approved cables . . . . . 5
  
- Chapter 2**
- Antenna parts and required tools. . . . . 7**
- Antenna kit components . . . . . 8
  - Related components . . . . . 8
  - Two antenna kits for two radio types . . . . . 8
  - Inspecting the antenna parts . . . . . 9
  - Description of main components . . . . . 10
    - Az/EI and reflector bracket assembly . . . . . 10
    - Antenna reflector . . . . . 11
    - Feed support tube and feed rods . . . . . 12
    - Feed horn and waveguide transition . . . . . 13
    - Radio mounting adapter . . . . . 14
    - Radio mounting brackets (for J-type radio only). . . . . 14
- Radio assembly types . . . . . 15
  - J-type radio assembly . . . . . 15
    - Vertical shim kit (if required) . . . . . 15
  - Cradle-type radio assembly . . . . . 16

Small hardware parts lists. . . . .	18
Additional parts for J-type radio. . . . .	19
Tools. . . . .	20

**Chapter 3**

<b>Assembling the antenna. . . . .</b>	<b>21</b>
Determining the pointing values . . . . .	21
General instructions for assembling the antenna . . . . .	22
Installing the Az/EI and reflector bracket assembly. . . . .	23
Attaching the reflector . . . . .	25
Installing the feed support tube . . . . .	27
Attaching the feed rods. . . . .	27
Securing the feed support tube . . . . .	28
Tightening the hardware. . . . .	29

**Chapter 4**

<b>Installing a J-type radio assembly . . . . .</b>	<b>31</b>
Installing a shim for vertical transmit polarization . . . . .	32
Installing the radio assembly . . . . .	36
Attaching the upper mounting bracket . . . . .	36
Attaching the feed horn and transition to the radio assembly	37
Mounting the radio assembly on the feed support tube . . . . .	39

**Chapter 5**

<b>Installing a cradle-type radio assembly . . . . .</b>	<b>43</b>
Installing the radio assembly . . . . .	44
Attaching the feed horn . . . . .	44
Mounting the radio assembly on the feed support tube . . . . .	45
Setting polarization for the cradle-type radio. . . . .	47
Calculating the radio polarization setting. . . . .	47
For a horizontal uplink /vertical downlink . . . . .	47
For a vertical uplink/ horizontal downlink. . . . .	47
Setting the radio polarization . . . . .	48

**Chapter 6**

<b>Cabling and connections . . . . .</b>	<b>49</b>
Previous cabling work . . . . .	49
Routing the cables at the ODU. . . . .	50
Ground connection . . . . .	51
Connecting the transmit and receive cables . . . . .	52
Transmit cable . . . . .	52
Receive cable . . . . .	54

<b>Chapter 7</b>	
<b>Pointing the antenna</b>	<b>55</b>
Antenna pointing overview	56
Using the installation software	56
Peaking the signal (description)	56
Personnel requirements	57
Pointing parameters	57
Prerequisites for antenna pointing	57
Outdoor pointing interface	57
Installing the OPI	58
OPI block	58
Adjusting the antenna	59
Adjustment locations on the antenna	60
Setting coarse elevation	61
Fine elevation adjustment	62
Receive pointing	62
Initial elevation setting	63
Setting polarization	63
Setting azimuth	64
If you cannot detect a signal	65
Peaking the signal (procedure)	66
Isolating the transmit signal	67
Manual ACP test	67
Automatic ACP test	68
Final steps	69
Remove the OPI	69
Check for safety labels and signs	69
Subsequent steps	69
<b>Acronyms and abbreviations</b>	<b>71</b>
<b>Index</b>	<b>73</b>



# Figures

---

## **Chapter 1**

- 1. Hughes model AN6-098P .98 m satellite antenna with radio .....2

## **Chapter 2**

- 2. Shipping container contents—main components .....9
- 3. Az/EI and reflector bracket assembly (pre-assembled as one unit) .....10
- 4. Antenna reflector .....11
- 5. Feed support tubes (two types).....12
- 6. Feed rods (two types) .....12
- 7. Feed horn and waveguide transition.....13
- 8. Radio assembly mounting adapter .....14
- 9. Radio assembly mounting brackets and adapter.....14
- 10. J-type radio assembly .....15
- 11. Shim for vertical transmit polarization.....16
- 12. Cradle-type radio assembly (shown with mounting adapter).....16
- 13. Cradle-like rotation of the cradle-type radio assembly .....17

## **Chapter 3**

- 14. Making sure the mast is plumb.....23
- 15. Az/EI and reflector bracket assembly on the mast .....24
- 16. Reflector in correct position for installation.....25
- 17. Mounting the reflector on the reflector bracket .....26
- 18. Attaching feed rods to the reflector .....27
- 19. Attaching the feed rods to the feed support tube .....28
- 20. Attaching the feed support tube to the reflector rim.....28
- 21. Tightening nuts on feed rods and feed support tube.....29
- 22. Completed antenna assembly (without radio) .....29

## **Chapter 4**

- 23. Shim location next to TRIA .....32
- 24. Horizontal shim and vertical shim for transmit polarization .....33
- 25. Direction of TRIA rotation for vertical polarization .....34
- 26. TRIA position for horizontal and vertical transmit polarization .....35
- 27. Attaching the upper mounting bracket .....36
- 28. Feed horn with waveguide transition attached.....37
- 29. O-ring in groove in waveguide transition.....37
- 30. Attaching the waveguide transition to the TRIA .....38

31. Securing the feed horn clamp . . . . .	39
32. Attaching the radio assembly to the feed support tube. . . . .	40
33. Attaching the radio assembly to the feed support tube. . . . .	41

**Chapter 5**

34. Attaching the feed horn and radio assembly . . . . .	44
35. O-ring in groove . . . . .	45
36. Mounting the radio on the feed support tube . . . . .	46
37. Rear circular bracket with polarization scale . . . . .	48

**Chapter 6**

38. Transmit and receive cable configurations . . . . .	50
39. Ground screw on J-type radio assembly. . . . .	51
40. Ground screw on cradle-type radio assembly. . . . .	52
41. Transmit connector – J-type radio . . . . .	53
42. Transmit connector – cradle-type radio . . . . .	53
43. Receive connector – J-type radio . . . . .	54
44. Receive connector – cradle-type radio . . . . .	54

**Chapter 7**

45. OPI (optional pointing tool) . . . . .	57
46. OPI . . . . .	58
47. Adjusting elevation, polarization, and azimuth . . . . .	59
48. Pointing adjustments on the antenna—elevation, polarization, and azimuth. . .	60
49. Setting coarse elevation . . . . .	61
50. Fine elevation adjustment. . . . .	62
51. Polarization adjustment on the antenna . . . . .	63
52. Azimuth adjustments on the antenna . . . . .	64

# Tables

---

## *Chapter 2*

1. Two antenna kit configurations . . . . .	8
2. Small hardware parts used in antenna kits for both radio types . . . . .	18
3. Additional small hardware parts included in the antenna kit for the J-type radio assembly . . . . .	19
4. Tools required to install and point the antenna. . . . .	20
5. Tool sizes matched to hardware sizes. . . . .	20

## *Chapter 3*

6. Torque specifications . . . . .	22
------------------------------------	----





# About this document

---

---

## Scope and audience

This manual explains how to assemble, install, and point the Hughes model AN6-098P .98 m antenna. It is written for qualified installers who are familiar with satellite antenna installation practices and are capable of properly applying the information presented.

---

## Organization

This manual is divided into the following chapters and appendix:

- Chapter 1 – *Overview* includes a summary of the installation steps and tells you where to find information about tasks related to antenna installation.
- Chapter 2 – *Antenna parts and required tools* describes the parts provided in the antenna kit and tools required for antenna installation.
- Chapter 3 – *Assembling the antenna* provides instructions for assembling and installing the antenna.
- Chapter 4 – *Installing a J-type radio assembly* provides instructions for installing the J-type radio assembly.
- Chapter 5 – *Installing a cradle-type radio assembly* provides instructions for installing the cradle-type radio assembly.
- Chapter 6 – *Cabling and connections* provides information about making connections to the radio assembly.
- Chapter 7 – *Pointing the antenna* explains how to point the antenna at the satellite, connect the transmitter, and acquire the satellite signal.

An acronyms and abbreviations list and an index are included at the back of the manual.

---

## Related publications

The *HN System Antenna Site Preparation and Mount Installation Guide* (1035678-0001) contains detailed information about:

- Safety considerations for mount and antenna installations
- Site surveys
- Trimasts and other types of antenna mounts
- Antenna installations on various types of surfaces
- Requirements for antennas that will be used in a Ka-band system or will later be upgraded for use in a Ka-band system

Additional related publications are identified in *Tasks related to antenna installation* on page 4.

---

## Revision record

This section describes the revision history of this manual.

Revision	Date of issue	Scope
A	March 2, 2007	Initial release

# Chapter 1

## Overview

---

This chapter presents an overview of the Hughes model AN6-098P .98 m Ku-band antenna in the following sections:

- *The model AN6-098P antenna* on page 2
- *Antenna installation summary* on page 3
- *Tasks related to antenna installation* on page 4

---

## The model AN6-098P antenna

Each remote terminal at a customer site requires an antenna and radio assembly to communicate with the system satellite and the Network Operations Center (NOC). The antenna is connected to the remote terminal (also known as the *indoor unit*, or IDU) by a transmit cable and a receive cable.

The Hughes model AN6-098P .98 m Ku-band antenna is designed for both Ku-band and Ka-band applications. Figure 1 shows the model AN6-098P antenna, installed, with a radio assembly.



Figure 1: Hughes model AN6-098P .98 m satellite antenna with radio

---

## Antenna installation summary

The antenna installation steps and related tasks are summarized below. **The steps in bold type are documented in this manual.**

1. Choose an installation site.
2. Select a method for mounting the antenna.
3. Install the antenna mount.



Note: A critical requirement is that the mast must be plumb. The antenna assembly cannot be adjusted to correct for a mast that is not plumb.

4. Install the IDU.



Note: Install the IDU before installing the antenna so you can use the installation software to determine the pointing values (azimuth, elevation, and polarization).

5. **Determine the pointing values (azimuth, elevation, and polarization)** – Chapter 3
6. **Install the Az/EI and reflector bracket assembly on the mast** – Chapter 3
7. **Install the antenna reflector** – Chapter 3
8. **Install the feed rods and feed support tube** – Chapter 3
9. **Install the radio assembly** – Chapter 4 (J-type radio) or Chapter 5 (cradle-type radio)



Note: The J-type and cradle-type radio assemblies are described in *Radio assembly types* on page 15.

10. Run cables between the IDU and ODU locations.
11. Ground the antenna assembly.
12. **Connect cables to the ODU** – Chapter 6
13. **Point the antenna** – Chapter 7

For the steps *not* shown in bold type, see the following section, *Tasks related to antenna installation*.



Note: *Outdoor unit* (ODU) refers to the antenna, radio assembly, and antenna mount.

Follow all steps in the order they are presented. Do not tighten any hardware until you are instructed to do so.

---

## Tasks related to antenna installation

This section explains where you can find information on tasks related to antenna installation.

### Selecting the installation site

Factors you should consider in selecting an installation site are discussed in the HN System *Antenna Site Preparation and Mount Installation Guide* (1035678-0001). The installation site and mounting method may be specified in the customer-specific installation specification.

### Installing the antenna mount

A suitable antenna mount must be installed before the antenna can be installed. Acceptable mounting methods are:

- Non-penetrating mount
- Trimast (may be used on a wood-frame roof or wood or masonry wall)
- Pole or pedestal mount

Most installations in a commercial, industrial, or institutional environment use a non-penetrating roof mount.

For pole or pedestal mounts that require a concrete base, you must allow at least 24 hr for the concrete to cure before you can install the antenna. Plan accordingly.

For complete information concerning antenna mount installation, refer to:

- The customer-specific installation specification
- The HN System *Antenna Site Preparation and Mount Installation Guide*

The customer-specific installation specification may include customer-specific guidelines concerning mount installation. Use only the mounting method described in the specification. For mount installation instructions, see the HN System *Antenna Site Preparation and Mount Installation Guide*.

### Installing the IDU

See the installation manual for the IDU (also referred to as a *remote terminal*.)

### Grounding

The entire antenna assembly must be grounded. For grounding information, refer to your training; best grounding practices; the Hughes Field Service Bulletin (FSB), *HNS Broadband Requirements for RG-6 and RG-11 IFL Cable Connectors, Ground Blocks and Ground Block Location* (FSB 50518\_01C); and applicable parts of the National Electrical Code (NEC).

**Approved cables** For a list of approved cables for the interfacility link (IFL) between the antenna and the remote terminal, see the Hughes FSB, *IFL Cable, Approved List (with lengths) for DW7x00, DW60xx, and DW40xx Domestic Installations* (FSB\_060316\_01A). The FSB lists the maximum cable length for each approved cable type, for both 1-W and 2-W radios.

How the cable is run depends on the specific installation site. Route and connect the IFL cable according to your training and best practices.





# Antenna parts and required tools

---

This chapter describes the parts provided in the model AN6-098P antenna kit. It includes the following sections:

- *Antenna kit components* on page 8
- *Radio assembly types* on page 15
- *Small hardware parts lists* on page 18
- *Tools* on page 20

## Antenna kit components

This section describes the main components of the .98 m antenna kit:

- Az/EI and reflector bracket assembly
- Antenna reflector
- Feed support tube and feed rods
- Feed horn
- Mounting parts for radio assembly

For details see *Description of main components* on page 10.

**Related components** The following are related components that are not part of the antenna kit:

- Radio assembly (J-type or cradle-type) – See *Radio assembly types* on page 15.
- Antenna mount – For general information about antenna mounts, see *Installing the antenna mount* on page 4.

## Two antenna kits for two radio types

You can install the .98 m antenna with either of two radio types, the *J-type radio* or *cradle-type radio*, which are described in *Radio assembly types* on page 15.

To support these two radio types, the antenna kit is available in two configurations, as listed in Table 1. In this manual, *the antenna kit* is used to refer to either kit.

Each antenna kit consists of two boxes of parts, as detailed in Figure 2. Most parts are common to both antenna kits. The main parts that are different in the two kits are the feed support tube, feed rods, and parts used to mount the radio assembly.

*Before proceeding, refer to Table 1 and make sure you have the correct antenna kit.*

Table 1: Two antenna kit configurations

Box contents	Hughes part number for each box
Antenna kit for J-type radio	
Box 1 – Az/EI and reflector bracket assembly, feed horn, mounting brackets and adapter for radio assembly, waveguide transition, and other parts.	P/N 1501111-0001
Box 2 – Reflector, feed support tube, feed rods, and other parts.	P/N 1501111-0002
Antenna kit for cradle-type radio	
Box 1 – Az/EI and reflector bracket assembly, feed horn, adapter for radio assembly, and other parts.	P/N 1501111-0021
Box 2 – Reflector, feed support tube, feed rods, and other parts.	P/N 1501111-0022
Box 1 is labeled <i>Box 1 of 2</i> . Box 2 is labeled <i>Box 2 of 2</i> .	

## Inspecting the antenna parts

The antenna kit for each radio type is shipped in two boxes, as shown in Figure 2. The radio assembly is shipped separately. As soon as possible, unpack and inspect the antenna parts and hardware to make sure all parts have been received in good condition.

Each main part is illustrated in the following sections, and the small hardware parts are listed in Table 2 and Table 3 on page 19. If any parts appear to have been damaged in transit, immediately contact the freight carrier. If any parts appear to be missing or damaged but *not* as a result of handling in transit, contact your dealer or distributor.

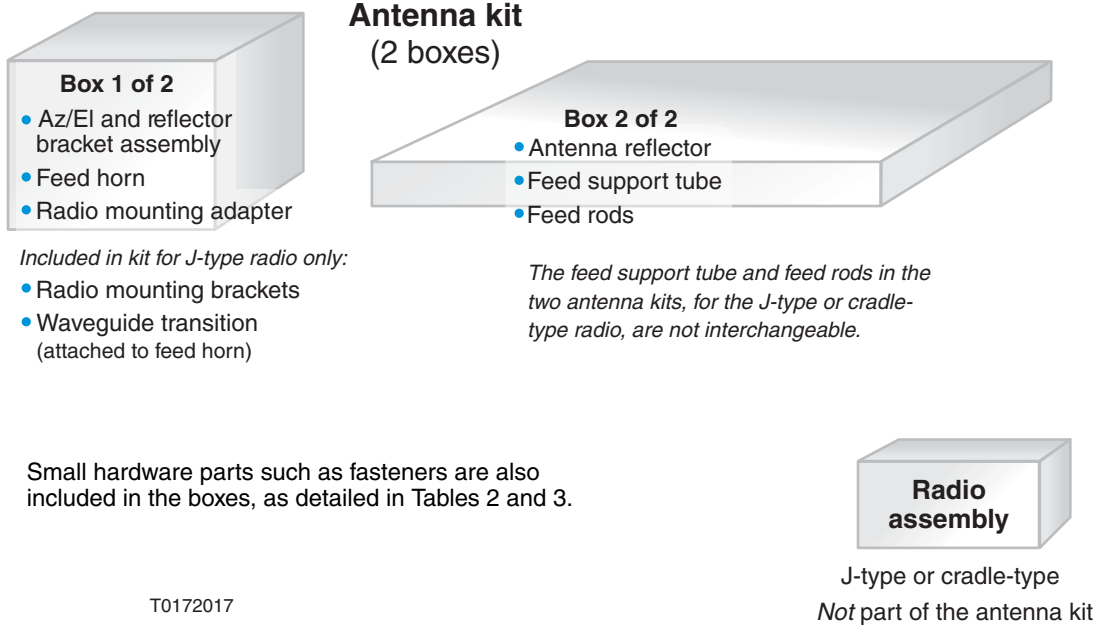

Small hardware parts such as fasteners are also included in the boxes, as detailed in Tables 2 and 3.

Figure 2: Shipping container contents—main components

**Description of main components**

The following sections describe and illustrate the antenna assembly's main components.

***Az/EI and reflector bracket assembly***

The Az/EI mount assembly and reflector bracket assembly are pre-assembled for installation as a single unit, as shown in Figure 3. The Az/EI mount assembly supports the antenna and is used to point the antenna at the satellite. The reflector bracket supports the antenna reflector.



Figure 3: Az/EI and reflector bracket assembly (pre-assembled as one unit)

**Antenna reflector** The antenna reflector is shown in Figure 4.



Figure 4: Antenna reflector

**Feed support tube and feed rods** The radio assembly mounts onto the feed support tube (Figure 5). The feed rods (Figure 6) attach to the reflector and support the feed support tube.

Each of the two antenna kits contains one feed support tube and two feed rods, for the radio type supported by the specific antenna kit. Figure 5 shows both types of feed support tubes for the two radio types. The feed support tube for the cradle-type radio is stamped *TG*. Other letters or numbers may appear with *TG*.

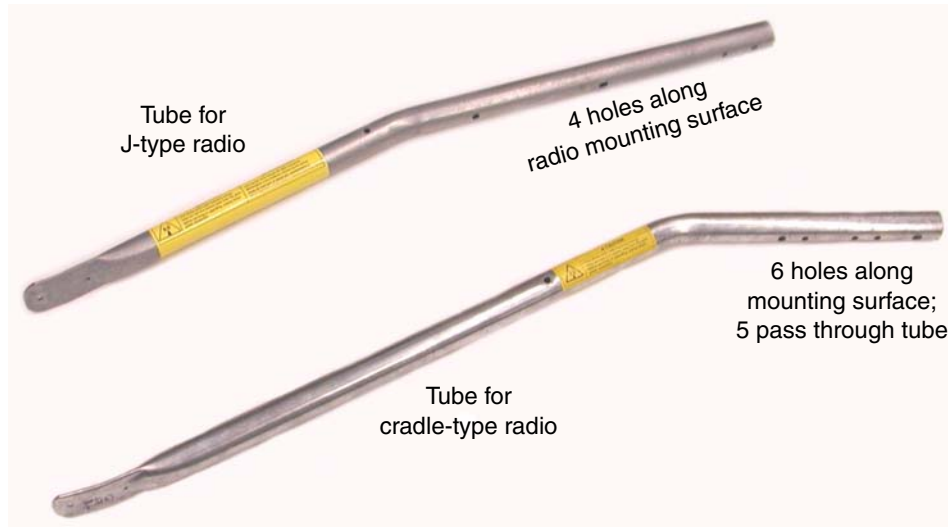

Figure 5: Feed support tubes (two types)

Figure 6 shows the two types of feed rods for the two radio types. The rods in the two antenna kits (for each radio type) are different lengths and are not interchangeable. The feed rods for the cradle-type radio are stamped *TG*. Other letters or numbers may appear with *TG*.

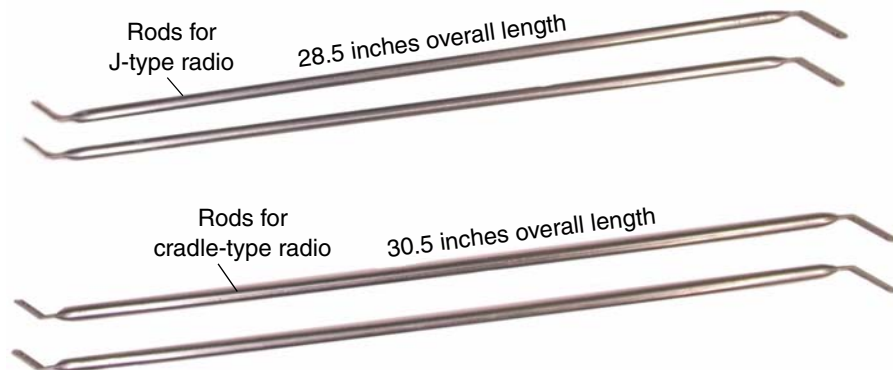

Figure 6: Feed rods (two types)

The feed support tube and the feed rods are the only main parts included in both antenna kits that are different.

**Feed horn and waveguide transition**

The feed horn (Figure 7) transmits and receives signals to and from the reflector.

The J-type radio assembly requires a waveguide transition, as shown in Figure 7. In the antenna kit for the J-type radio, the transition is attached to the feed horn at the factory, as shown in Figure 7. As explained later in this manual, you attach the transition the radio assembly.

The antenna kit for the cradle-type radio does not include a waveguide transition because the feed horn attaches directly to the cradle-type radio assembly.

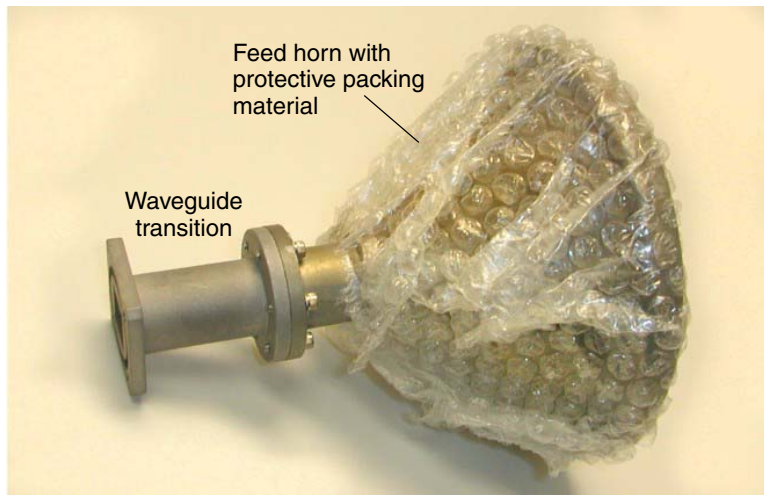

Figure 7: Feed horn and waveguide transition

---

**CAUTION**

- Do not remove the protective packing material from the feed horn window until installation of the radio assembly is complete.
  - Do not attempt to remove the feed horn window at any time.
  - Be careful not to damage the feed horn window. Do not touch the plastic film.
-

**Radio mounting adapter** The mounting adapter shown in Figure 8 is used for both radio types to mount the radio assembly on the feed support tube.

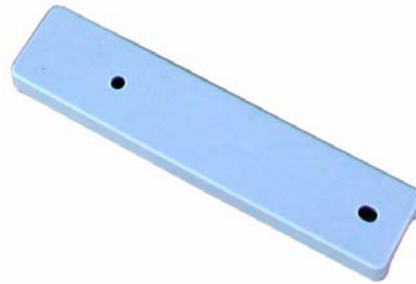

Figure 8: Radio assembly mounting adapter

**Radio mounting brackets (for J-type radio only)** The antenna kit for the J-type radio assembly (only) includes two mounting brackets (Figure 9) that are used to secure the radio assembly to the feed support tube, as illustrated in Figure 10 on page 15.

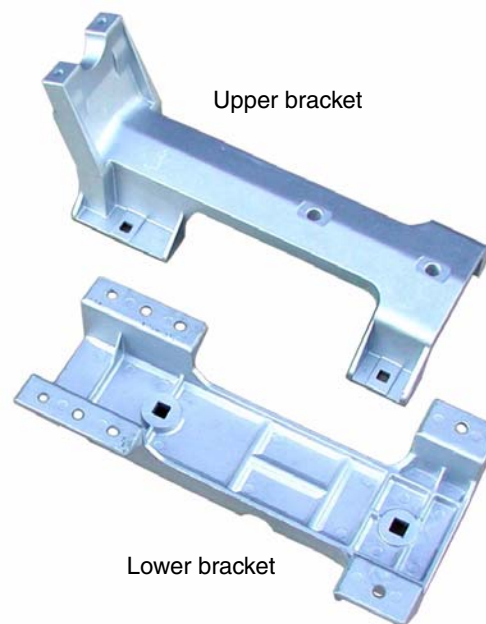

Figure 9: Radio assembly mounting brackets and adapter



---

## Radio assembly types

The radio assembly is not part of the antenna kit; however, radio assembly installation is included in this manual because the antenna and radio assembly are usually installed at the same time. There are two possible radio assemblies available for the .98 m antenna, the J-type radio assembly or cradle-type radio assembly.

**J-type radio assembly** Figure 10 shows the *J-type* radio assembly, referred to as *J-type* because its waveguide is shaped something like the letter J.

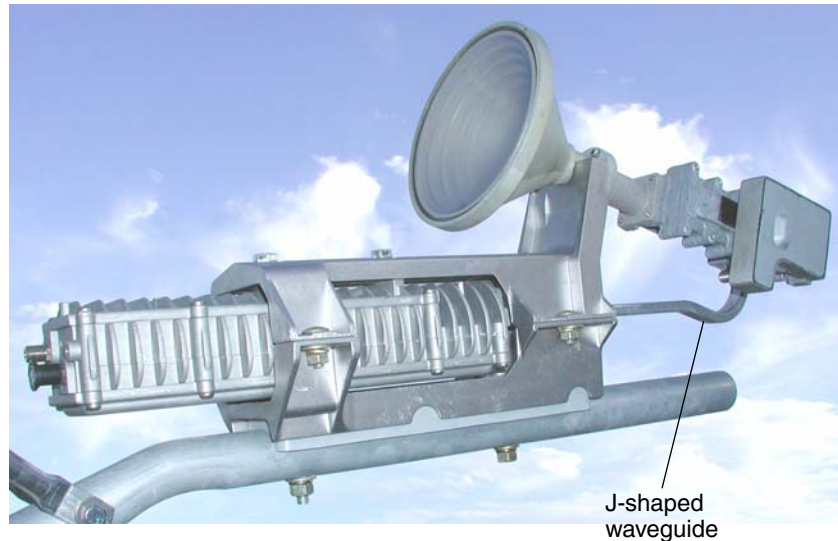

Figure 10: J-type radio assembly

*J-type* refers to the overall design of the radio; therefore, two radios with different model numbers may both be J-type radios.

### **Vertical shim kit (if required)**

A vertical transmit shim kit may be required for the J-type radio assembly only. If the installation specification states that vertical transmit polarization is required, you will need to obtain and install a vertical shim kit (Figure 11) in the radio assembly. Otherwise, a vertical shim is not required. For more information,

see *Installing a shim for vertical transmit polarization* on page 32.



Figure 11: Shim for vertical transmit polarization

***Cradle-type radio assembly*** Figure 12 illustrates the *cradle-type* radio assembly. The main parts of the radio assembly are mounted on two circular brackets so they can be rotated, similar to the movement of a cradle, to set the polarization of the feed horn. The arrows in Figure 13 indicate how the radio assembly can be rotated.

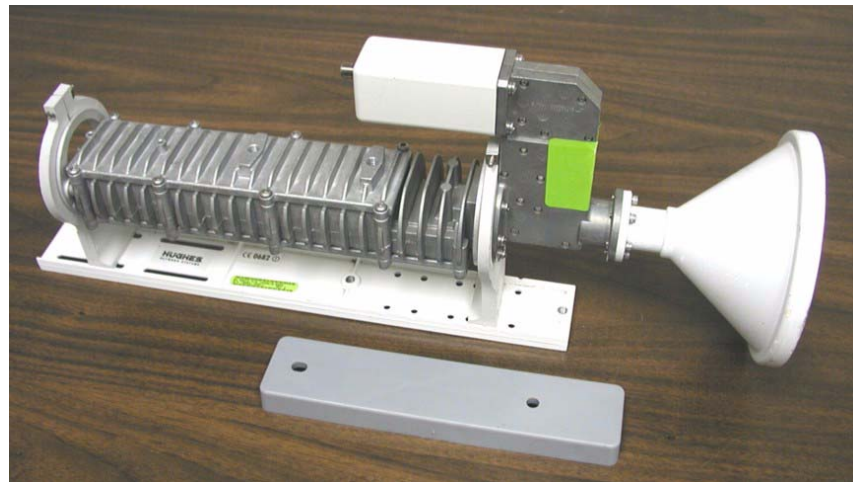

Figure 12: Cradle-type radio assembly (shown with mounting adapter)

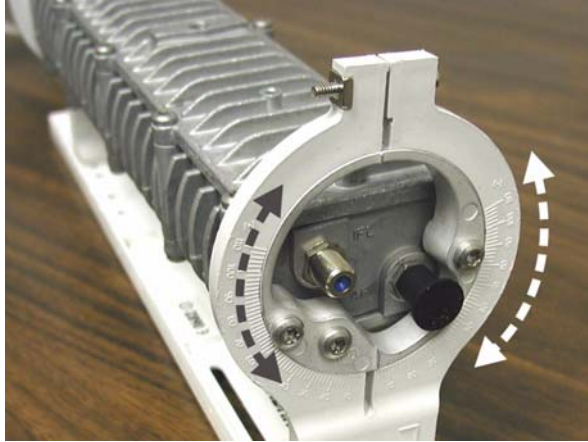

Figure 13: Cradle-like rotation of the cradle-type radio assembly

*Cradle-type* refers to the overall design of the radio; therefore, two radios with different model numbers may both be cradle-type radios.

## Small hardware parts lists

Tables 2 and 3 list the small hardware parts included in the antenna kits for the two radio types (J-type and cradle-type).

The parts listed in Table 2 are included in *both kits*, for both radio assembly types.

Table 2: Small hardware parts used in antenna kits for both radio types

Part	Quantity	Comments
For assembling the antenna		
¼-20 × 1-3/8-inch thread-cutting screws	4	These parts are used for attaching the: <ul style="list-style-type: none"> <li>• Reflector</li> <li>• Feed rods</li> <li>• Feed support tube</li> </ul>
¼-20 × 1-inch hex bolts	3	
¼-20 × 2-inch hex bolt	1	
¼-inch flat washers	8	The hardware for each task is specified in Chapter 3 – <i>Assembling the antenna</i> .
¼-inch lock washers	4	
¼-inch hex nuts	4	
For mounting the radio assembly (both types)		
0.9-inch inside diameter O-ring *	1	These parts are used for both radio assemblies, to: <ul style="list-style-type: none"> <li>• Attach the feed horn</li> <li>• Mount the radio assembly</li> </ul>
No. 6-32 × 0.5-inch socket-head cap screws *	7	
No. 6 internal tooth lock washers *	7	The hardware for each task is specified in: <ul style="list-style-type: none"> <li>• Chapter 4 – <i>Installing a J-type radio assembly</i></li> <li>• Chapter 5 – <i>Installing a cradle-type radio assembly</i></li> </ul>
Silicone grease capsule	1	
5/16-18 × 2.25-inch carriage bolts	2	
5/16-inch flat washers	4	
5/16-inch lock washers	4	
5/16-inch hex nuts	2	

\* In the antenna kit for the J-type radio, the waveguide transition is attached to the feed horn at the factory, so these parts are factory installed.

**Additional parts for J-type radio**

The parts listed in Table 3 are included *only* in the antenna kit for the J-type radio. The antenna kit for the J-type radio also includes the part listed in Table 2.

Table 3: Additional small hardware parts included in the antenna kit for the J-type radio assembly

Part	Quantity	Comments
1-inch inside diameter O-ring	1	These parts are used to attach the: <ul style="list-style-type: none"> <li>• Waveguide transition to the radio assembly</li> <li>• Upper mounting bracket to the transmitter</li> <li>• Upper and lower mounting brackets to each other</li> </ul>
M4 x 12-mm socket-head cap screws	4	
M4 lock washers	4	
5/16-18 x 1-inch hex bolts	2	The hardware for each task is specified in Chapter 4 – <i>Installing a J-type radio assembly.</i>
¼-20 x 1-inch hex bolts	2	
¼-20 x 0.75-inch carriage bolts	4	
¼-inch flat washers	4	
¼-inch lock washers	6	
¼-inch hex nuts	4	
Feed horn clamp	1	

## Tools

Table 4 lists the tools required to install and point the antenna.

Table 4: Tools required to install and point the antenna

Tool	Details
(2) 7/16-inch combination wrenches *	For ¼-inch bolts. Some nuts and bolts require a second wrench to prevent turning.
(2) ½-inch combination wrenches *	For 5/16-inch bolts. Two of the canister nuts are not accessible with a socket wrench. Some nuts and bolts require a second wrench to prevent turning.
Torque wrench	With ½-inch and 7/16-inch sockets capable of torquing to 15 ft-lb.
M7 hex key	For J-type radio.
7/64-inch hex key	For cradle-type radio. The 7/64-inch hex key is included in the antenna kit.
Long-shaft hexagonal ball driver, 3-mm	For socket-head cap screws (Allen screws) with a 3-mm hexagonal socket. Driver shaft should be at least 5 inches long. (Recommended for attaching or removing the J-type radio assembly to or from the waveguide transition. A short-arm hex key is provided with the screws, but the long-shaft ball driver is much easier. The long-shaft ball driver cannot be used for the cradle-type radio.)
Torque wrench for hexagonal socket	Must fit a 3-mm hexagonal socket and be capable of torquing to 15 inch-lb.
Bubble level	Used to make sure the mast is plumb.
Compass	Hand-held, magnetic.
Pencil	Carpenter's pencil.
Outdoor pointing interface (OPI)	Optional. Hughes P/N 1031393-0002. Portable repeater that displays signal strength values during antenna pointing. For additional information, see <i>Installing the OPI</i> on page 58.
Ladder	If needed.

\* A socket wrench with 7/16-inch and ½-inch sockets makes some tasks easier, but for some nuts or bolts there is not enough clearance to use a socket wrench.

See the HN System *Antenna Site Preparation and Mount Installation Guide* (1035678-0001) for a more complete list of tools and items that may be needed for installation.

Table 5 specifies the correct tool size for each hardware size included in the antenna kit:

Table 5: Tool sizes matched to hardware sizes

Hardware size	Tool size
¼-inch	7/16-inch
5/16-inch	½-inch
#6-32 socket-head cap screw	7/64-inch hex key
M4 x 20 mm screw	M7 key wrench

# Assembling the antenna

---

This chapter explains how to install:

- **The Az/El and reflector bracket assembly** – The Az/El mount assembly and reflector bracket assembly are pre-assembled for installation as a single unit, as shown in Figure 3 on page 10.
- **The antenna reflector**
- **The feed rods and feed support tube** – The feed rods attach to the reflector and help support the feed support tube.

Radio installation is covered in Chapter 4 for the J-type radio and Chapter 5 for the cradle-type radio.

Topics in this chapter include:

- *Determining the pointing values* on page 21
- *General instructions for assembling the antenna* on page 22
- *Installing the Az/El and reflector bracket assembly* on page 23
- *Attaching the reflector* on page 25
- *Installing the feed support tube* on page 27

---

 **CAUTION**



**Before you install the antenna, read all safety information in the section titled *Important safety information* on page iii.**

---

---

## Determining the pointing values

*Satellite-based commissioning* (SBC) is an automated web-based method for pointing the antenna. SBC configures the IDU, calculates its exact location, and uses the location and other information to help you point the antenna. SBC calculates the values you use to set the antenna's azimuth, elevation, and polarization, based on the information you enter and the satellite you select. It then downloads the necessary software and completes the IDU registration process.

In this manual, *installation software* refers to installation, pointing, and commissioning software accessed through the IDU, which works in conjunction with SBC.

Before proceeding, use the installation software to determine the initial values to use for setting azimuth, elevation, and polarization. Record these values and keep them handy for reference as you install and point the antenna. To use the installation software, follow the instructions in the IDU installation manual for commissioning the IDU.

## General instructions for assembling the antenna

Before you assemble the antenna, read these important instructions:

- **Mast** – *The mast must be installed before you can install the antenna.* For information on antenna mounting methods, see the HN System *Antenna Site Preparation and Mount Installation Guide* (1035678-0001). The mast must have an outside diameter of 2-<sup>3</sup>/<sub>8</sub> inches (2.375 inches).
- **Sequence of steps** – When you assemble the antenna, *follow the instructions in this chapter in the order they are presented.*
- **Tightening hardware**– *Do not tighten any nuts or other hardware until you are instructed to do so.* (See also the next item, Torque.)
- **Torque** – To ensure successful installation of the antenna, you *must* tighten all nuts and socket-head cap screws to the maximum torque values shown in Table 6. This is a critical requirement.

Table 6: Torque specifications

Fastener	Maximum torque
¼-inch bolts	6 ft-lb
5/16-inch bolts	15 ft-lb
¼-20 thread-cutting screws used to secure reflector bracket to reflector	10 ft-lb
No. 6-32 and M4 socket-head cap screws	15 inch-lb

For bolts that use a split lock washer, tighten the bolt until the washer is flattened, but do not tighten the bolt further. When the washer is flattened, this indicates that sufficient torque has been applied.



## Installing the Az/EI and reflector bracket assembly

Follow these steps to install the Az/EI and reflector bracket assembly onto the mast:

1. Before you install the Az/EI and reflector bracket assembly onto the mast pipe, use a bubble level to make sure the mast is plumb.

Check the mast at two perpendicular locations, as shown in Figure 14.



Note: The mast must be plumb. The antenna assembly cannot be adjusted to correct for a mast that is not plumb.

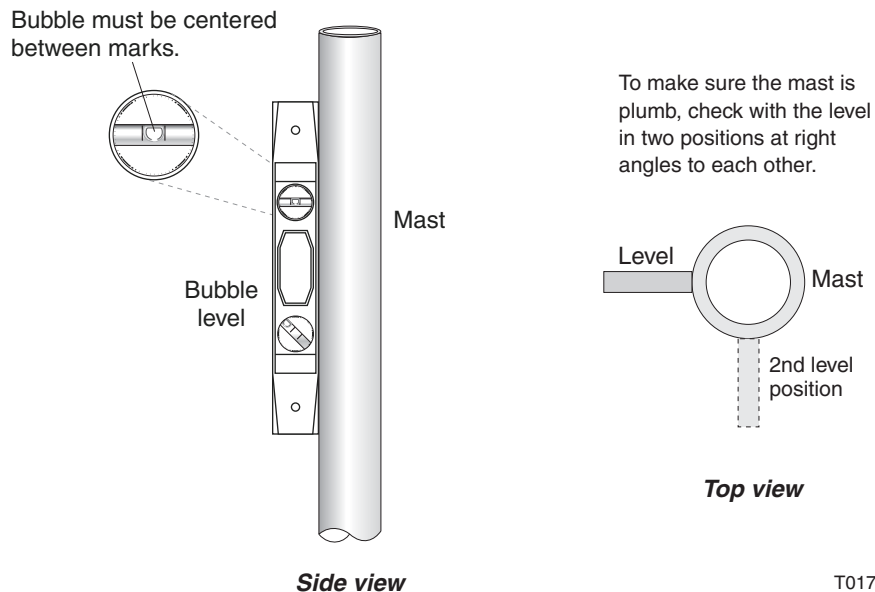

Figure 14: Making sure the mast is plumb

2. Slide the canister of the Az/EI and reflector bracket assembly down onto the mast.

Figure 15 shows the Az/EI and reflector bracket assembly on the mast.



Note: The mast must have an outside diameter of  $2\frac{3}{8}$  inches (2.375 inches).



Figure 15: Az/EI and reflector bracket assembly on the mast

3. *Optional:* If you adjust the antenna elevation now to the coarse elevation value, before installing the reflector, it's easier than making this adjustment after the reflector is attached. You can make this adjustment now or do it as part of the antenna pointing procedure. (See *Setting coarse elevation* on page 61.)
4. Rotate the Az/EI and reflector bracket assembly until the reflector side is oriented in the general direction of the satellite.  
If necessary, loosen the canister nuts just enough to allow the assembly to rotate.
5. Snug the three canister nuts just enough to prevent the assembly from rotating. Do not tighten the nuts at this time.

---

## Attaching the reflector

Follow these instructions to attach the antenna reflector to the reflector bracket.



Note: This task is easier if someone assists you.

1. Orient the reflector so the HughesNet logo on the front is near the top, as shown in Figure 16.

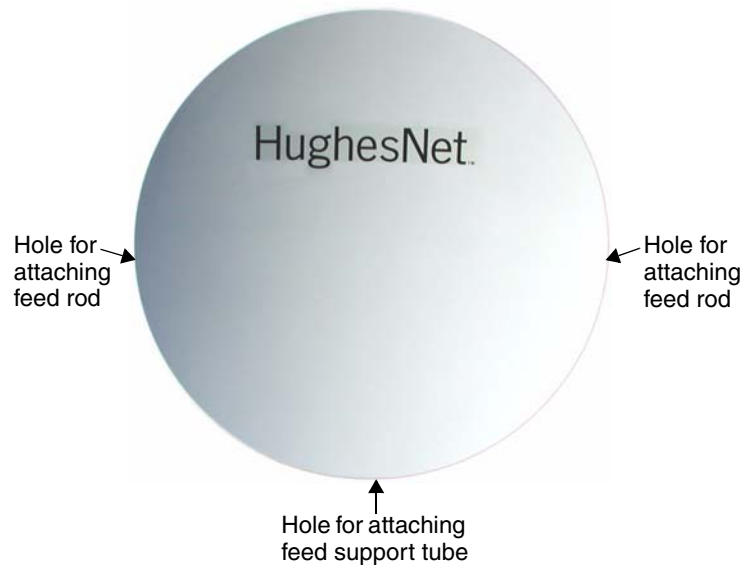

Figure 16: Reflector in correct position for installation

2. Lift the reflector and align the four mounting holes on the back of the reflector with the four mounting holes on the reflector bracket. See Figure 17.



Note: To make it easier to position the reflector and insert the screws (steps 2 and 3), you can adjust the elevation of the Az/El and reflector bracket assembly beyond the 80° mark on the elevation scale so the surface of the reflector bracket that attaches to the reflector is nearly horizontal. Then you can lay the reflector on the bracket, with the holes in the reflector facing the bracket. This method (not illustrated here) is especially useful when one person installs the antenna.

To use this method you must loosen the fine elevation adjustment nuts and elevation lockdown bolts identified in Figure 48 on page 60. Be sure to tighten the elevation lockdown bolts before laying the reflector on the bracket.

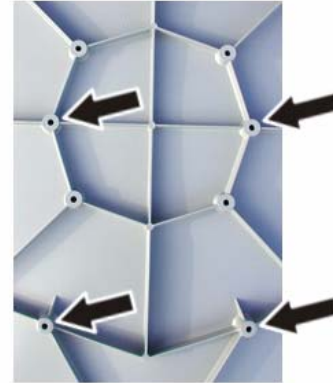

Mounting holes (arrows)  
on back of reflector

Reflector attached to bracket

Arrows above point to mounting screws. One screw, indicated by the gray arrow, is not visible in this photo.

Figure 17: Mounting the reflector on the reflector bracket

3. Insert two  $\frac{1}{4}$ -20  $\times$  1- $\frac{3}{8}$ -inch hex thread-cutting screws (without washers) through the upper holes on the reflector bracket and into the reflector holes indicated in Figure 17 (upper arrows on the right photo).
4. Partially tighten the screws.
5. Insert two  $\frac{1}{4}$ -20  $\times$  1- $\frac{1}{16}$ -inch hex thread-cutting screws (without washers) through the lower holes on the reflector bracket and into the lower reflector holes.
6. Tighten each screw a little; then move on to the next screw.
7. Use a torque wrench to tighten the screws to 10 ft-lb force maximum.

---

## CAUTION

To avoid damaging the mounting holes in the back of the reflector, do not overtighten the reflector bracket screws. Use a torque wrench.

---

## Installing the feed support tube

Install the feed rods and feed support tube as explained in the following two sections. These instructions apply to *both* types of feed support tubes and feed rods, that is, the tube and feed rods for the J-type radio or cradle-type radio.



Note: If you are installing an antenna that will use a cradle-type radio assembly, make sure the feed support tube and feed rods are stamped *TG*. (Other letters or numbers may appear with *TG*.) If these parts are not stamped *TG*, they are the wrong parts for the cradle-type radio. Contact Installer Support to obtain the correct parts.

## Attaching the feed rods

Attach the feed rods to the reflector:

1. Attach the feed rods to the rim of the reflector as shown in Figure 18.

The feed rod end with the longer flat part attaches to the reflector rim; the end with the shorter flat part attaches to the feed support tube (as shown in Figure 19 on page 28).

Point the lower end of each feed rod inward, toward the space in front of the lower part of the reflector. When both feed rods are correctly installed, their lower ends are just a few inches apart.

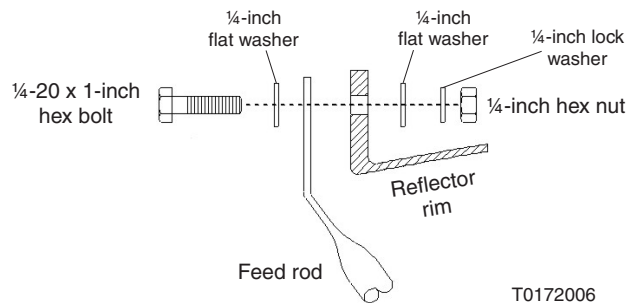

Figure 18: Attaching feed rods to the reflector



Note: The photos in this section show the feed support tube and rods for the J-type radio. These parts for the cradle-type radio are very similar and are installed in the same way.

2. Tighten each nut just enough to keep the hardware in place.

## Securing the feed support tube

Secure the feed support tube:

1. Attach the lower ends of the feed rods to the feed support tube as follows: Insert the  $\frac{1}{4}$ -20  $\times$  2-inch hex bolt through the tube, and use the hardware shown in Figure 19. Make sure the flat end of the feed support tube points toward the reflector.
2. Tighten the nut just enough to keep the hardware in place.



Feed rod ends attached to feed support tube, in front of reflector

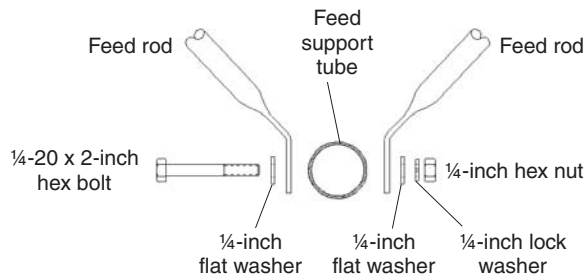

Detail

T0172007

Figure 19: Attaching the feed rods to the feed support tube

3. Attach the flat end of the feed support tube to the rim of the reflector, as shown in Figure 20.
4. Tighten the nut just enough to keep the hardware in place.



Back of reflector  
Rim  
Flat end of feed support tube

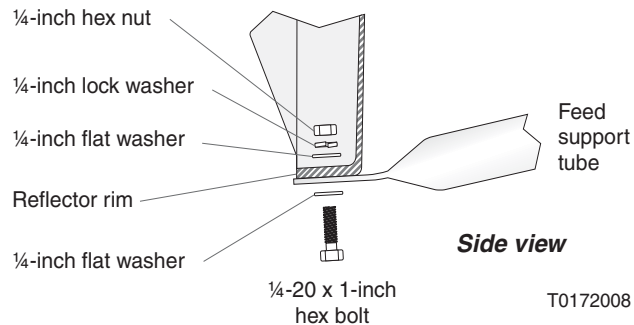

Side view

Detail

T0172008

Figure 20: Attaching the feed support tube to the reflector rim



**Tightening the hardware** Tighten the hardware as follows:

1. Tighten the three nuts on the reflector rim (indicated by the black arrows in Figure 21).
2. Tighten the nut where the feed rods attach to the feed support tube (indicated by the white arrow in Figure 21).



Figure 21: Tightening nuts on feed rods and feed support tube

The antenna is now assembled, as shown in Figure 22, and ready for installation of the radio assembly.

- If you are installing a J-type radio, go to Chapter 4 – *Installing a J-type radio assembly*, on page 31.
- If you are installing a cradle-type radio, go to Chapter 5 – *Installing a cradle-type radio assembly*, on page 43.



Figure 22: Completed antenna assembly (without radio)





# Installing a J-type radio assembly

---

*This chapter applies to the J-type radio assembly only. If you are installing a cradle-type radio assembly, go to Chapter 5 – Installing a cradle-type radio assembly, on page 43.*

This chapter includes:

- *Installing a shim for vertical transmit polarization on page 32*
- *Installing the radio assembly on page 36*

---

## CAUTION

- **Do not remove the protective packing material from the feed horn window until installation of the radio assembly is complete.**
  - **Do not remove the protective covering from the small end of the feed horn until you are ready to attach the waveguide transition.**
  - **Be careful not to damage the feed horn window. Do not touch the plastic film.**
-

---

## Installing a shim for vertical transmit polarization

Follow the instructions in this section only if the installation specification or service order states that vertical transmit polarization is required. (The vertical shim kit is *not* used with the cradle-type radio.)

If vertical transmit polarization is not required, go to *Installing the radio assembly* on page 36.

The radio assembly is shipped with a horizontal transmit polarization shim installed. If vertical transmit polarization is required, you must remove the horizontal shim and replace it with a vertical transmit polarization shim.



Note: If you need to change from horizontal to vertical transmit polarization on an antenna that has the radio assembly already installed on the feed support tube, you will have to remove the radio assembly from the feed support tube before you can follow the instructions in this section.

Figure 23 shows where the shim is located and shows three of the four Allen screws that hold the shim in place.

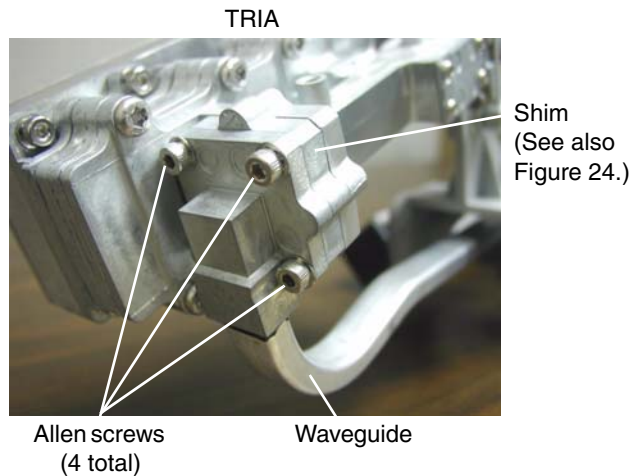

Figure 23: Shim location next to TRIA

To replace the horizontal shim with a vertical shim, follow these steps:

1. Obtain a vertical transmit polarization shim kit (Hughes model VTX-SHIM-KIT, P/N 1033809-0001).  
Figure 24 on page 33 shows what a vertical shim looks like.
2. Loosen and remove the four Allen screws that hold the shim in place. See Figure 23.
3. Separate the end of the waveguide from the shim.

Figure 24 illustrates the difference between the horizontal shim and vertical shim. Note the positions of the alignment pins.

X here identifies horizontal shim. This X is visible when the parts are assembled.

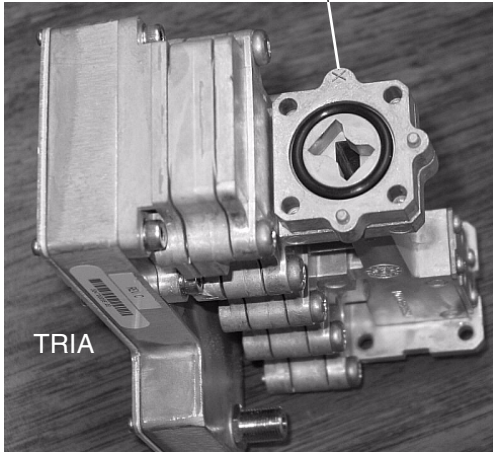

**Horizontal shim in place**

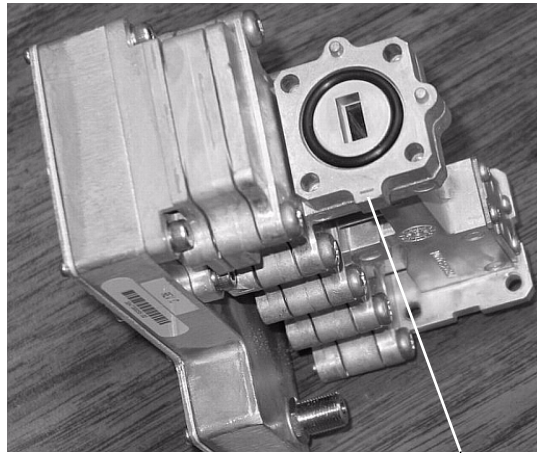

**Vertical shim in place**

(In this photograph, the TRIA has not yet been rotated.)

"-" mark here identifies vertical shim. This mark is visible when the parts are assembled.

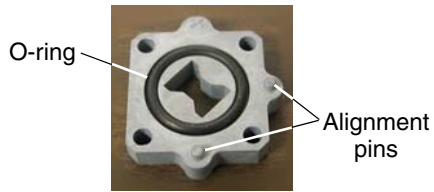

Horizontal shim

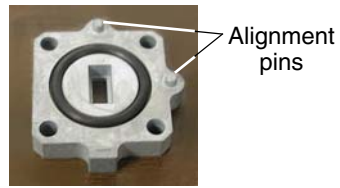

Vertical shim

Figure 24: Horizontal shim and vertical shim for transmit polarization

4. Remove the horizontal shim and O-ring.

5. Install the vertical shim and O-ring in the same location. Because of its shape and alignment pins on the transmit/receive isolation assembly (TRIA), the vertical shim can only be installed in the position shown in Figure 24 (upper right photo). Note the position of the alignment pins. Likewise, the horizontal shim can only be installed in one position. Because of the shim's alignment pins, you must rotate the TRIA 90° from its horizontal polarization position. You must rotate the TRIA *before* you re-attach the waveguide end so you can insert the shim alignment pins into the waveguide end plate. See Figures 25 and 26.

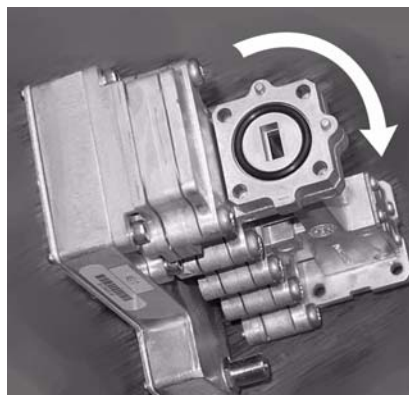

Figure 25: Direction of TRIA rotation for vertical polarization

Figure 26 shows how the TRIA is positioned for horizontal transmit polarization compared to how it is positioned for vertical transmit polarization.



Horizontal polarization



TRIA rotated for vertical polarization

Figure 26: TRIA position for horizontal and vertical transmit polarization

6. Make sure the O-ring shown in Figure 25 on page 34 is in place in the shim.
7. With the TRIA correctly positioned (rotated), place the waveguide end plate against the shim.
8. Insert and tighten the four Allen screws.

At this point the radio assembly is ready to be installed.

---

## Installing the radio assembly

This section explains how to install the J-type radio assembly. You must use the antenna kit indicated in Table 1 on page 8 for the J-type radio assembly.

### Attaching the upper mounting bracket

Attach the upper mounting bracket to the transmitter:

1. Place the upper mounting bracket onto the transmitter, in the position shown in Figure 27.

Align the two bolt holes in the bracket with the holes in the transmitter.

2. Secure the bracket to the transmitter with two  $\frac{5}{16}$ -18  $\times$  1-inch hex bolts, lock washers, and flat washers.
3. Tighten the bolts.

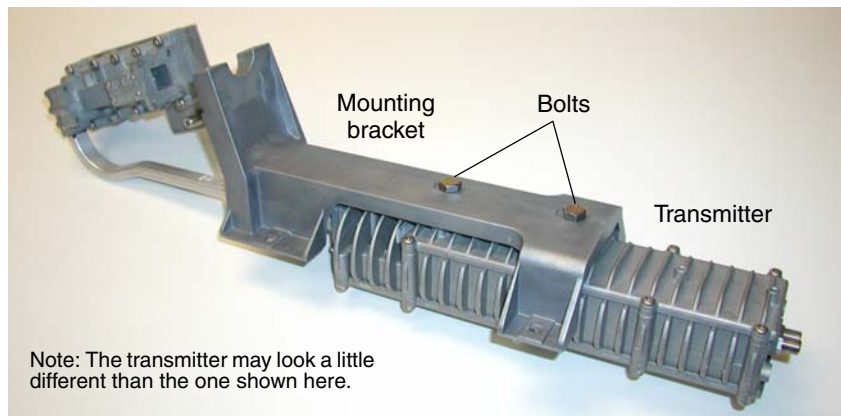

Figure 27: Attaching the upper mounting bracket

## Attaching the feed horn and transition to the radio assembly

The feed horn and waveguide transition are shipped from the factory pre-attached, as shown in Figure 28.

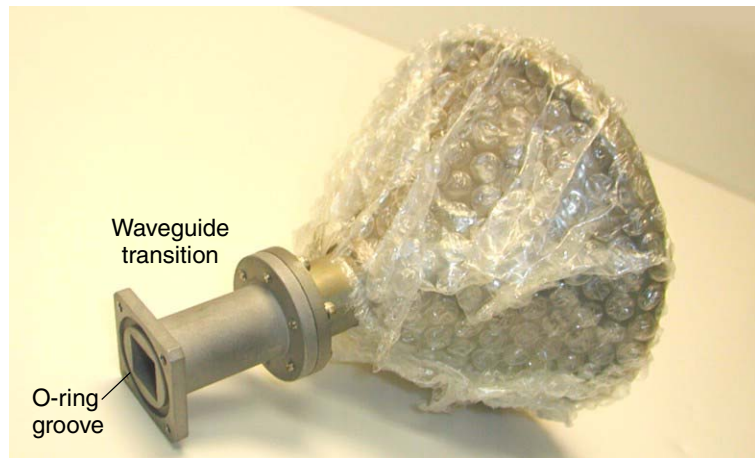

Figure 28: Feed horn with waveguide transition attached

Attach the square end of the waveguide transition (with the feed horn attached) to the radio assembly—specifically, to the transmit/receive isolation assembly, or TRIA:

1. Apply silicone grease to the O-ring groove in the waveguide transition. See Figure 29.  
The silicone grease is provided in a small plastic capsule.
2. Place the O-ring (1-inch inside diameter) in the O-ring groove in the square end of the waveguide transition.



Note: The O-ring and small hardware for the square end of the waveguide transition are shipped in a bag that contains four socket-head cap screws.

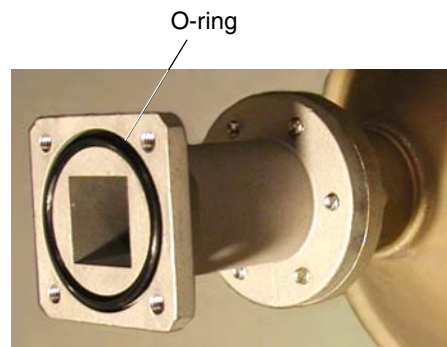

Figure 29: O-ring in groove in waveguide transition



3. Place the neck of the feed horn into the upper mounting bracket, and position the square end of the waveguide transition close to the TRIA. See Figure 30.

Make sure the feed horn packing material is out of the way so it will not get stuck between the feed horn neck and the upper mounting bracket.

4. Attach the square end of the waveguide transition to the TRIA using the provided M4 × 12-mm socket-head cap screws and M4 lock washers with teeth on the inner edges. (See Figure 30.)

Insert the screws in the direction indicated by the white arrows in Figure 30.

*Make sure the O-ring remains in the O-ring groove.*

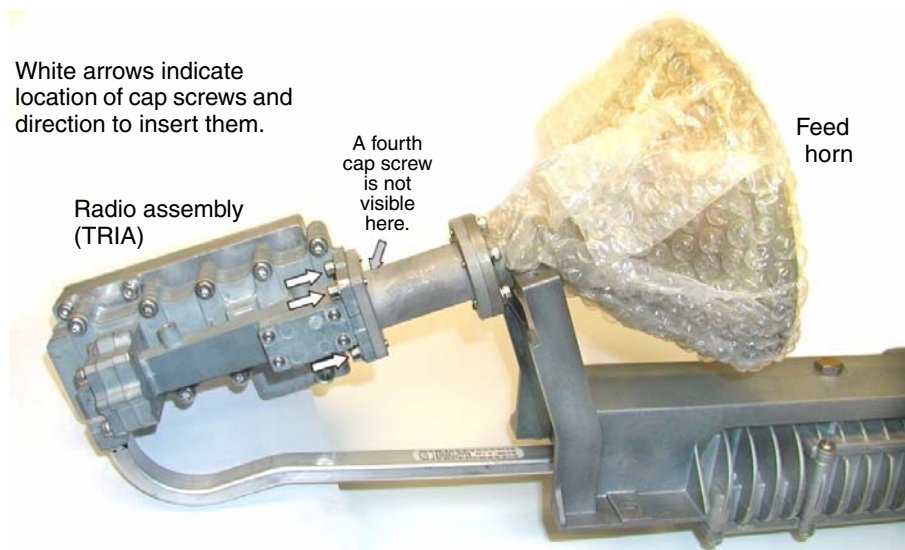

Figure 30: Attaching the waveguide transition to the TRIA

5. Use a long-shaft 3-mm ball driver to tighten the M4 cap screws.
6. Place the feed horn clamp over the neck of the feed horn, as shown in Figure 31.
7. Insert two ¼-20 × 1-inch hex bolts (with lock washers)—one on each side of the clamp.  
Make sure the packing material is out of the way so it will not get stuck under the clamp.



8. Tighten the bolts alternately, a little at a time.

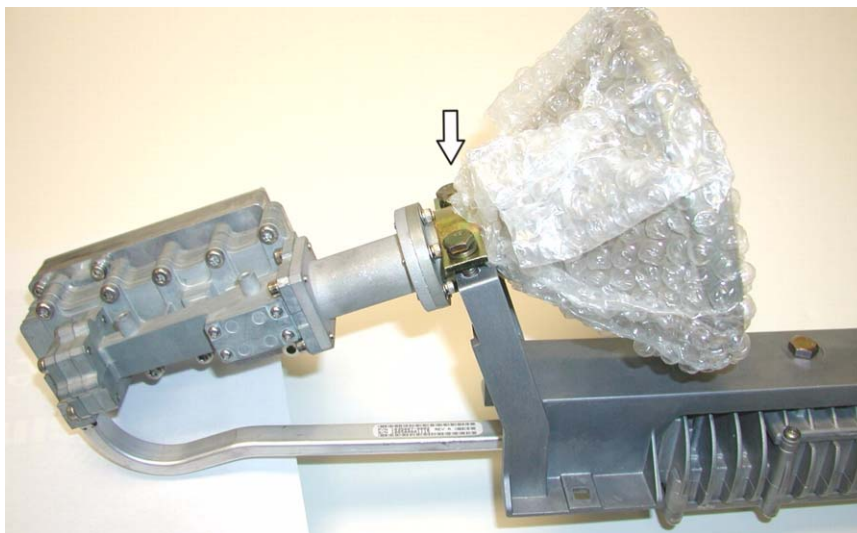

Figure 31: Securing the feed horn clamp (arrow)

**Mounting the radio assembly on the feed support tube**

To mount the radio assembly on the feed support tube, first mount the lower mounting bracket on the feed support tube:

1. Position the lower mounting bracket and mounting adapter on the feed support tube, with the bolt holes aligned, as shown in Figure 32.

There are four holes on the top surface of the feed support tube. Two of these holes are oval slots. Use the round hole and oval slot *closest to the reflector* to mount the radio. (See Figure 32.)

2. Insert two  $\frac{5}{16}$ -18  $\times$  2.5-inch carriage bolts from above, one into each of the two mounting holes.
3. From below, place a  $\frac{5}{16}$ -inch flat washer, lock washer, and hex nut on each bolt.

4. Tighten the nuts.

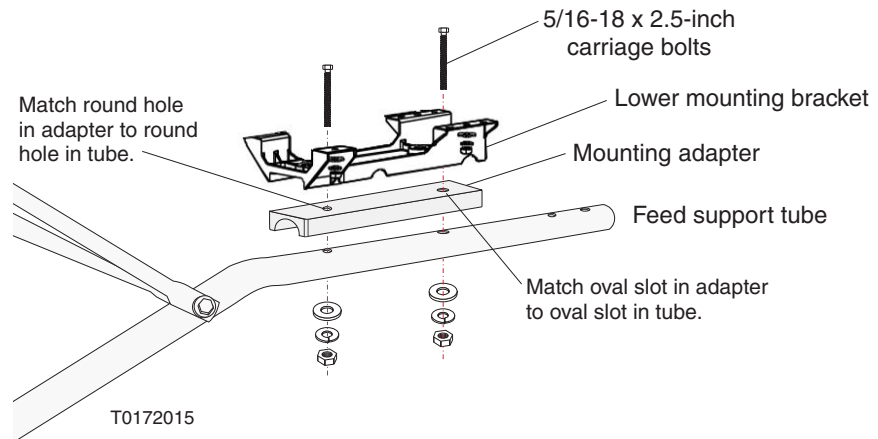

Figure 32: Attaching the radio assembly to the feed support tube

Attach the upper and lower mounting brackets to each other, as shown in Figure 33:

1. Place the radio assembly (attached to the upper bracket in previous steps) onto the lower bracket.
2. Align the four mounting holes on the upper and lower mounting brackets.
3. Insert a  $\frac{1}{4}$ -20  $\times$  0.75-inch carriage bolt through each of the four mounting holes.
4. From below, place a  $\frac{1}{4}$ -inch flat washer, lock washer, and hex nut on each bolt.

5. Tighten the four bolts.

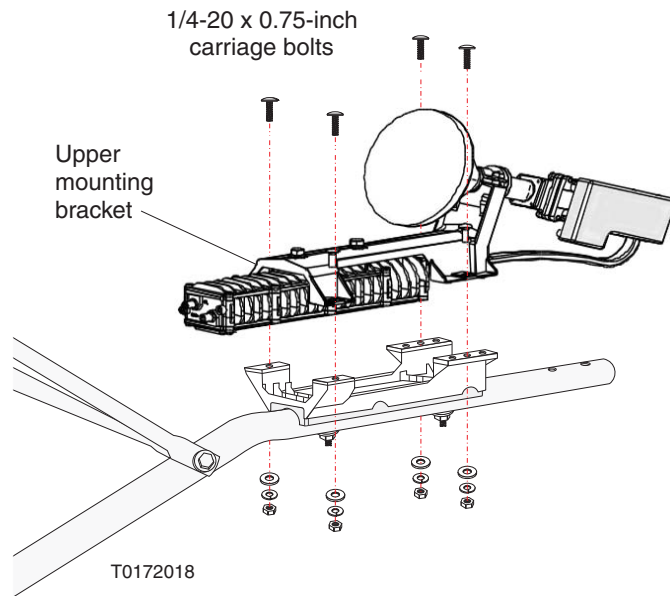

Figure 33: Attaching the radio assembly to the feed support tube

6. Remove the protective packing material from the feed horn window.

This completes installation of the radio assembly.



# Installing a cradle-type radio assembly

---

*This chapter applies to the cradle-type radio assembly only. If you are installing a J-type radio assembly, go to Chapter 4 – Installing a J-type radio assembly, on page 31.*

This chapter includes:

- *Installing the radio assembly* on page 44
- *Setting polarization for the cradle-type radio* on page 47

---

## CAUTION

- **Do not remove the protective packing material from the feed horn window until installation of the radio assembly is complete.**
  - **Be careful not to damage the feed horn window. Do not touch the plastic film.**
-

---

## Installing the radio assembly

This section explains how to install the cradle-type radio assembly. You must use the antenna kit indicated in Table 1 on page 8 for the cradle-type radio assembly.

- Attaching the feed horn**
7. To attach the feed horn to the radio assembly, refer to Figures 34 and 35 and follow steps 1 through 3 below.

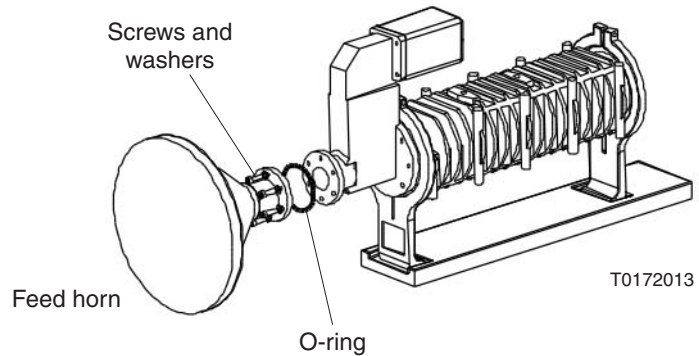

Figure 34: Attaching the feed horn and radio assembly

1. Remove the protective covering from the small end of the feed horn.

---

### CAUTION

- If you do not remove the protective covering from the small end of the feed horn, the system may operate, but with degraded performance.
  - Do not remove the protective packing material from the feed horn *window* until you finish installation of the radio assembly.
-

2. Apply silicone grease to the O-ring groove in the feed horn.
3. Place the O-ring (0.9-inch inside diameter) in the groove.



Note: The O-ring is shipped in a bag that contains seven socket-head cap screws for attaching the feed horn. Six screws are required; one is an extra part.

*Make sure the O-ring remains in the O-ring groove.*

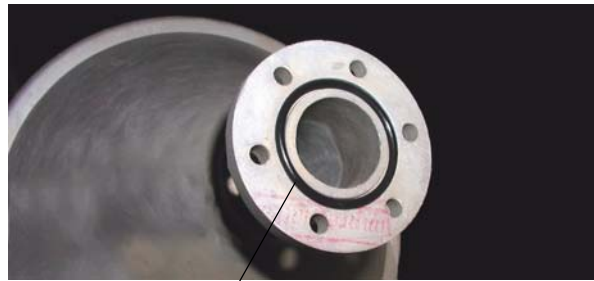

O-ring

Figure 35: O-ring in groove

### **Mounting the radio assembly on the feed support tube**

Use the mounting adapter to attach the radio assembly to the feed support tube. Refer to Figure 36 as you follow these instructions:

1. Place the mounting adapter and radio assembly onto the feed support tube.
2. Align the mounting holes in the base of the radio assembly, mounting adapter, and feed support tube.

There are six holes on the top surface of the feed support tube. Use the oval slot at the end of the tube and the second hole from the bend in the tube, as shown in Figure 36.

3. From below, insert two  $\frac{5}{16}$ -18  $\times$  2.25-inch hex bolts (using a  $\frac{5}{16}$ -inch lock washer and flat washer on each bolt) through the feed support tube, adapter, and base.

4. Tighten the bolts securely.

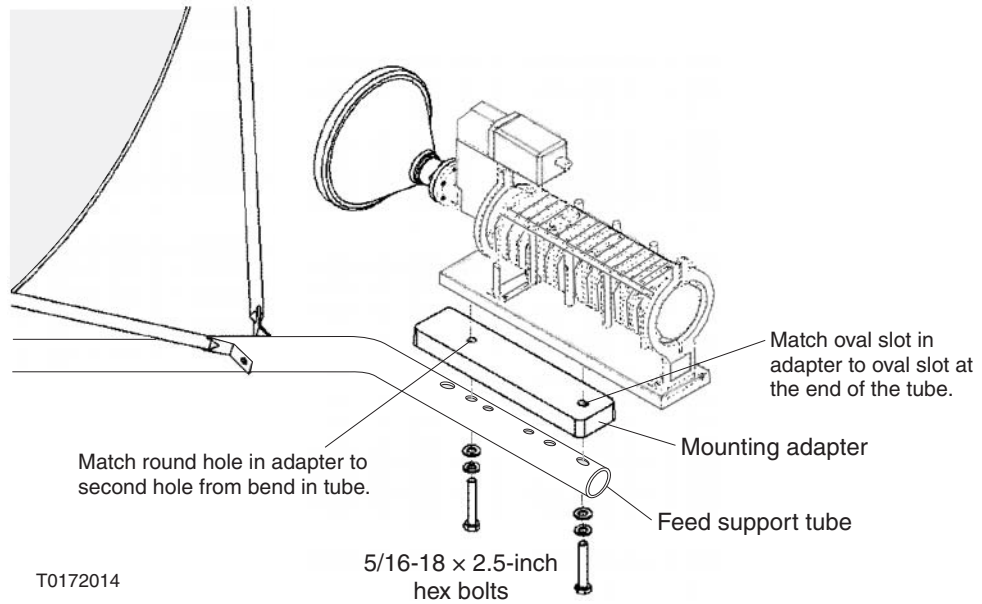

Figure 36: Mounting the radio on the feed support tube

5. Remove the protective packing material from the feed horn window.

This completes installation of the radio assembly.



---

## Setting polarization for the cradle-type radio

To set polarization for the cradle-type radio, you adjust the radio, not the antenna. This section explains how to calculate and set the polarization value for the cradle-type radio assembly.

### Calculating the radio polarization setting

To calculate the polarization setting, refer to the section for the type of uplink and downlink that will be used. In these instructions, *SBC initial value* refers to the polarization value calculated by the installation software.

#### ***For a horizontal uplink/vertical downlink***

To calculate the radio polarization setting for a horizontal uplink/vertical downlink:

1. Multiply the SBC initial value by  $-1$ , then offset the result by  $90^\circ$  as follows:  
If the SBC initial value is positive, *add* 90.  
If the SBC initial value is negative, *subtract* 90.

*Example 1, positive initial value of  $41^\circ$*

$$41 \times -1 = -41$$

*Add 90:*

$$-41 + 90 = 49$$

$$\text{Radio polarization setting} = 49^\circ$$

*Example 2, negative initial value of  $-41^\circ$*

$$-41 \times -1 = 41$$

*Subtract 90:*

$$41 - 90 = -49$$

$$\text{Radio polarization setting} = -49^\circ.$$

2. Make a note of the setting.
3. Go to *Setting the radio polarization* on page 48.

#### ***For a vertical uplink/horizontal downlink***

To calculate the radio polarization setting for a vertical uplink/horizontal downlink:

1. Multiply the SBC initial value by  $-1$  (with no offset).

*Example 1, SBC initial value of  $38^\circ$*

$$38 \times -1 = -38$$

$$\text{Radio polarization setting} = -38^\circ.$$

*Example 1, SBC initial value of  $38^\circ$*

$$-38 \times -1 = 38$$

$$\text{Radio polarization setting} = 38^\circ.$$

2. Make a note of the setting.
3. Go to *Setting the radio polarization* on page 48.

## Setting the radio polarization

Set polarization on the cradle-type radio as follows:

1. Before proceeding, make sure the *antenna* polarization is set to  $0^\circ$ . See *Setting polarization* on page 63.
2. On the radio assembly, loosen the two screws at the top of the two circular brackets at each end of the transmitter. (Each of these brackets has a polarization scale.) See Figure 37.

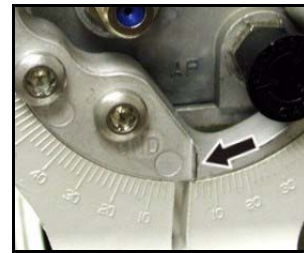
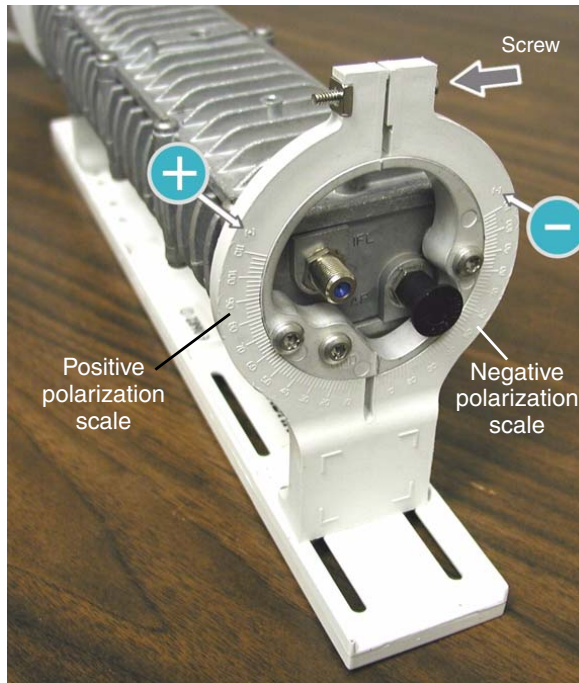

To set polarization, align marker indicated by black arrow to the desired value on the scale. The setting in this photo is close to  $0^\circ$ .

Figure 37: Rear circular bracket with polarization scale

3. Set the radio polarization to the calculated setting by rotating the radio and using the polarization scales on the circular brackets.  
Plus (+) and (-) minus signs at the top of each scale indicate positive or negative values. Make sure you read the correct scale.
4. Tighten the two screws on the circular bracket.

This completes installation of the radio assembly.

## Chapter 6

# Cabling and connections

---

This chapter illustrates where the ODU ground, transmit, and receive connectors are located; shows how to route the transmit and receive cables at the ODU; and explains how to connect the transmit and receive cables to the radio assembly. You must connect the transmit, receive, and ground cables before you can point the antenna (Chapter 7 – *Pointing the antenna*).

The chapter includes these sections:

- *Previous cabling work* on page 49
- *Routing the cables at the ODU* on page 50
- *Ground connection* on page 51
- *Connecting the transmit and receive cables* on page 52

---

### Previous cabling work

*Before you can complete the steps explained in this chapter, you must route and terminate the transmit and receive cables from the IDU to the ODU.*

For a list of approved cables for the IFL between the antenna and the remote terminal, see the Field Service Bulletin (FSB), *IFL Cable, Approved List (with lengths) for DW7x00, DW60xx, and DW40xx Domestic Installations* (FSB\_060316\_01A). This FSB lists the maximum cable length for each approved cable type, for both 1-W and 2-W radios.

How the cables are run depends on the specific installation site. Route and connect the cables according to your training and best practices.

---

### CAUTION

**Coaxial connectors and cable can corrode if exposed to moisture. Use *only* compression type connectors, and weatherproof them with dielectric grease and weatherproof tape.**

---



Note: For connector requirements, see the Hughes FSB, *HNS Broadband Requirements for RG-6 and RG-11 IFL Cable Connectors, Ground Blocks and Ground Block Location* (FSB 50518\_01C).

## Routing the cables at the ODU

Route the coaxial transmit and receive cables at the ODU as follows:

1. Route the transmit cable (marked with blue electrical tape) over the Az/EI and reflector bracket assembly and behind the reflector to the back of the transmitter, in a configuration similar to that shown in Figure 38.

Do not exceed the minimum bending radius specified by the cable manufacturer.

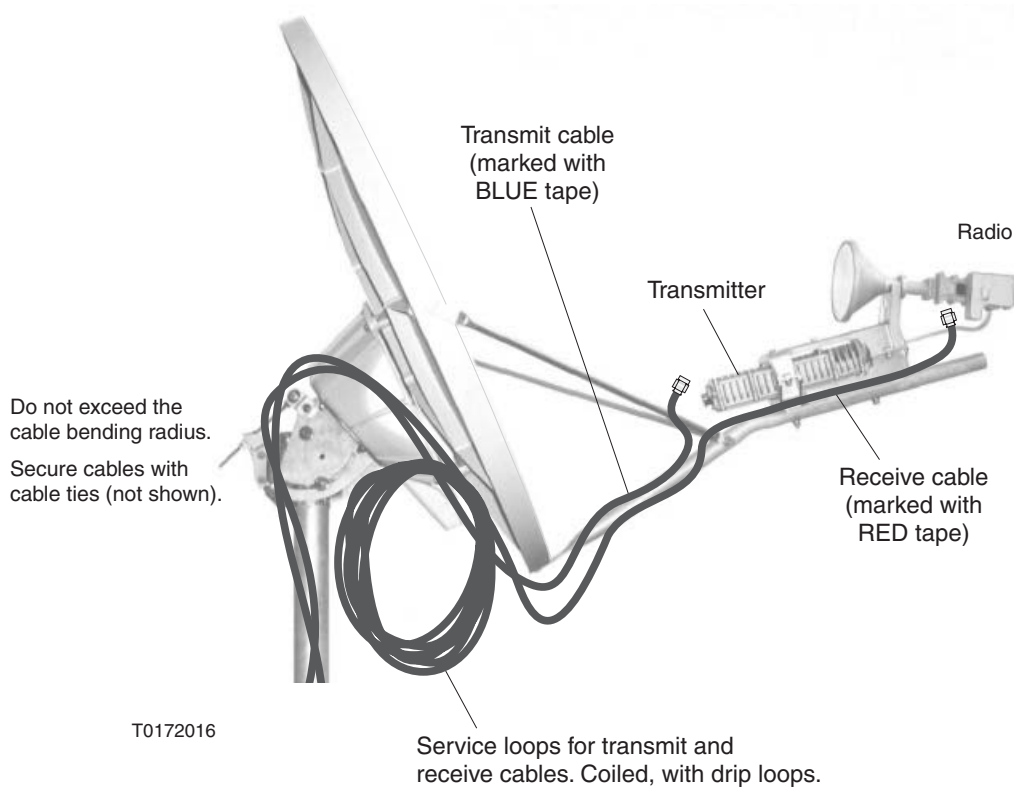

Figure 38: Transmit and receive cable configurations

2. For the transmit cable, leave a 152-inch service loop (12 ft 8 inches), secured to the mast, or Az/EI mount assembly. This allows 10 ft for a service loop plus 32 inches for installation of a future Ka-band radio upgrade.

Do *not* leave the service loop on the roof or other mounting surface.

Do not block access to the adjustment nuts on the canister and Az/EI mount assembly.

3. Coil the extra cable, leave a drip loop, and secure the transmit cable with cable ties.
4. Route the receive cable (marked with red electrical tape) over the Az/EI mount assembly, behind the reflector, and along the feed support tube to the TRIA, in a configuration similar to that shown in Figure 38.  
Do not exceed the minimum cable bending radius.
5. For the receive cable, leave a 138-inch service loop (11.5 ft), secured to the mast, Az/EI mount assembly, or reflector bracket. This allows 10 ft for a service loop plus 18 inches for installation of a future Ka-band radio upgrade.
6. Coil the extra cable, leave a drip loop, and secure the receive cable with cable ties.



Note: When you connect the cables, tighten all radio and ground block connectors with a torque wrench to 20 inch-lb.

## Ground connection

Ground the transmitter and mast. For specific grounding procedures, refer to the sources listed in *Grounding* on page 4.

Figure 39 shows the location of the ground screw on the J-type radio assembly. Figure 40 shows the ground screw on the cradle-type radio assembly.



Figure 39: Ground screw on J-type radio assembly (arrow)



Note: The transmitter may look a little different than the one shown in Figure 40, but the connectors are still on the end of the transmitter, as shown, and they are clearly marked: GND – ground. IFL – interfacility link, for transmit cable.

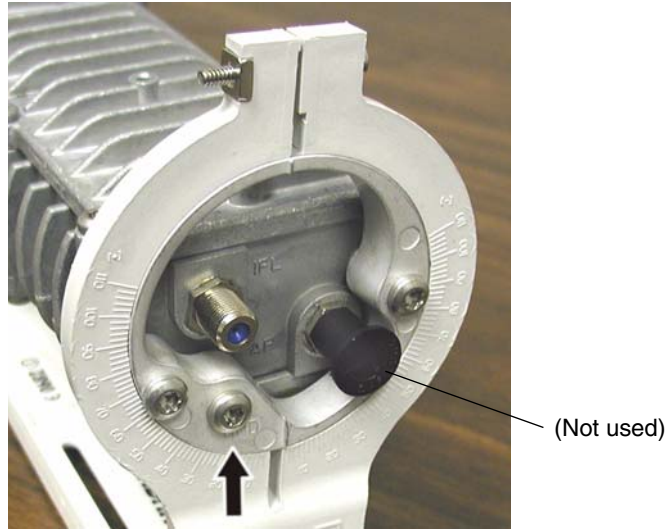

Figure 40: Ground screw on cradle-type radio assembly (arrow)

---

## Connecting the transmit and receive cables

This section explains how to connect the transmit and receive cables to the radio assembly.

### Transmit cable

Connect the transmit cable to the transmitter as follows:

1. From inside the building, disconnect the IDU power supply.
2. Go outside and connect the transmit cable (marked with blue electrical tape) to the transmitter connector marked *IFL*.

Figure 41 shows the transmit connector location for the J-type radio assembly, and Figure 42 shows the connector location for the cradle-type radio assembly. In both cases the connector is a female F connector.

---

## CAUTION

**Coaxial connectors and cable can corrode if exposed to moisture. Use *only* compression type connectors, and weatherproof them with dielectric grease and weatherproof tape.**

---

3. Use a  $\frac{7}{16}$ -inch torque wrench to tighten the connector to 20 inch-lb.

4. If necessary, secure the cable with cable ties.



Figure 41: Transmit connector – J-type radio



Figure 42: Transmit connector – cradle-type radio



**Receive cable** Connect the receive cable to the low noise block converter (LNB) as follows:

1. Connect the receive cable (marked with red tape) to the receive connector on the LNB.

Figure 43 shows the receive connector location on the J-type radio assembly, and Figure 44 shows the connector location on the cradle-type radio assembly. In both cases the connector is a female F connector.

2. Use a  $\frac{7}{16}$ -inch torque wrench to tighten the connector to 20 inch-lb.
3. Apply dielectric silicone grease to the connection.
4. If necessary, secure the cable with cable ties.

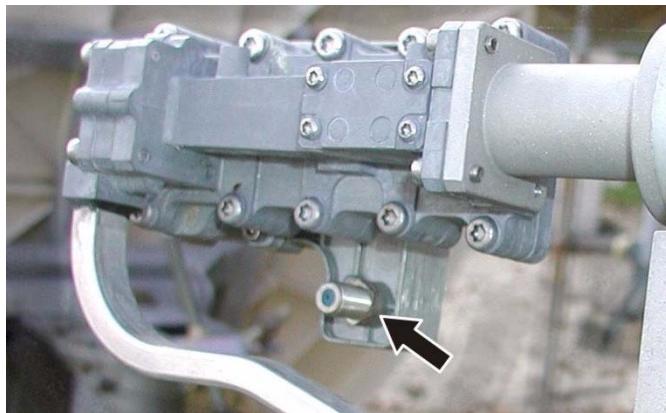

Figure 43: Receive connector – J-type radio



Figure 44: Receive connector – cradle-type radio

After the transmit and receive cables are connected to the radio and to the IDU, reconnect the power transformer (inside the building). Instructions for connecting the IDU are included in the IDU installation manual.



## Chapter 7

# Pointing the antenna

---

This chapter explains how to point the antenna. Topics include:

- *Antenna pointing overview* on page 56
- *Prerequisites for antenna pointing* on page 57
- *Outdoor pointing interface* on page 57
- *Adjusting the antenna* on page 59
- *Setting coarse elevation* on page 61
- *Fine elevation adjustment* on page 62
- *Receive pointing* on page 62
- *Isolating the transmit signal* on page 67
- *Final steps* on page 69

As you perform these procedures, observe the following safety precautions:

---

### CAUTION



- **This device emits radio frequency energy when in transmit mode. To avoid injury, do not place head or other body parts between feed horn and antenna when system is operational. Keep at least 2 ft away from the area between the feed horn and the reflector when the system is operational.**
  - **Make sure the cylindrical space projecting outward from the antenna reflector toward the satellite does not intersect or come close to any inhabited areas.**
  - **Disconnect power from the IDU before performing maintenance or adding upgrades to any antenna components.**
-

---

## Antenna pointing overview

This chapter describes a general procedure for pointing the antenna. The objectives of antenna pointing are to:

- Locate and detect the satellite signal
- Peak the signal to achieve the greatest possible signal strength

### Using the installation software

The IDU installation software guides you through a step-by-step process for installing the IDU and pointing the antenna. It calculates your exact location and the values you use to set elevation, polarization, and azimuth. (See also *Determining the pointing values* on page 21.)

Use the information in this chapter as a guide for the overall pointing process and for instructions on how to make mechanical adjustments to the antenna. For specific steps, follow the instructions in the IDU installation guide and on the installation software screens.

In general you will alternate between these two activities:

- Following the software prompts and instructions
- Adjusting the antenna (elevation, polarization, and azimuth) to acquire and then peak the satellite signal. The required adjustments are different for each installation location.

### Peaking the signal (description)

Correct antenna alignment is critical to the operation of the system. When the antenna is pointed directly at the satellite, it receives a strong signal. If it is not pointed properly, the signal may be weak, and errors may result during data transfers.

Antenna pointing is accomplished by first *receive pointing* the antenna and then *isolating the transmit signal*. Receive pointing adjusts the antenna to obtain the best receive signal. Isolating the transmit signal fine tunes the antenna alignment for the strongest possible signal received by the HN System NOC. Both processes are explained later in this chapter.

To point the antenna, you go through cycles of making small adjustments to the antenna until you are satisfied you cannot get a stronger satellite signal. When you have achieved the strongest possible signal, you have *peaked* the signal.

You may achieve the strongest signal strength after just a few adjustments, or you may find that several adjustments are needed. By obtaining the strongest possible signal you ensure that the terminal can operate with peak performance.

**Personnel requirements** One person can point the antenna if an outdoor pointing interface (OPI) is used. Otherwise, pointing is usually a two-person task. If an OPI is not used, one person aims and adjusts the antenna while the other watches the signal strength display on a computer and relays the readings to the person at the antenna. A portable telephone or walkie-talkie is helpful for this.

**Pointing parameters** Prior to antenna pointing, you use the installation software to enter parameters such as longitude, latitude, and polarization angle. Or you can enter the local ZIP code and let the software calculate these values.

---

## Prerequisites for antenna pointing

The following are required for antenna pointing:

- The antenna must be installed.
- The IDU must be installed.
- The transmit and receive cables must be connected to the IDU and ODU.
- The OPI, if used, must be installed. (See *Installing the OPI* on page 58.)
- The ODU and IDU must be grounded.
- You must have access to the installation software through the IDU.

---

## Outdoor pointing interface

The OPI (Hughes P/N 1031393-0002), shown in Figure 45, is an optional tool that displays signal strength values.

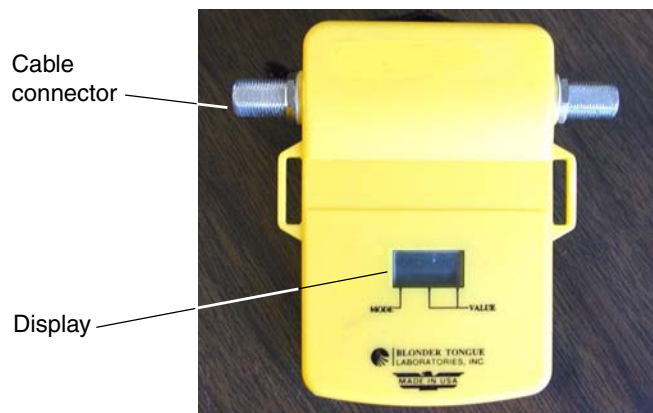

Figure 45: OPI (optional pointing tool)

**Installing the OPI** To prepare for antenna pointing, attach the OPI to the receive cable from the LNB, as shown in Figure 46. Note that the OPI will not work unless it is enabled on the appropriate screen on the installation software. (Check the box labeled Enable OPI Display.) For further details, see *Outdoor Pointing Interface Operating Instructions* (1031832-0001).

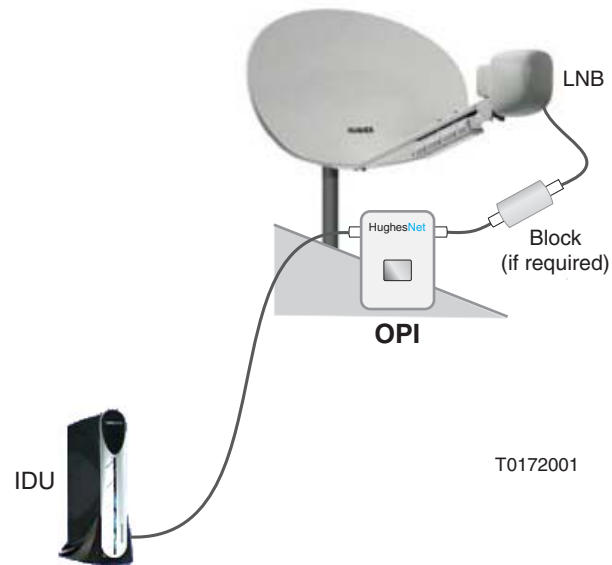

Figure 46: OPI

**OPI block** If you use an OPI with a model J-type radio assembly, you must use a block (or filter). For details, including the specific block you should use, see the Hughes Field Service Bulletin (FSB), *Standard OPI Configuration* (FSB\_060915\_01A).

Install the block between the OPI and the radio as illustrated in Figure 46. If the block you use has two female F connectors (at both ends), you will have to make a jumper cable to connect to the OPI.

## Adjusting the antenna

To point the antenna you make three adjustments to the position of the antenna reflector:

- Elevation – Adjustment up and down
- Polarization – Rotational adjustment
- Azimuth – Side-to-side adjustment

These adjustments are illustrated in Figure 47. The corresponding mechanical adjustments on the antenna are shown in Figure 48.

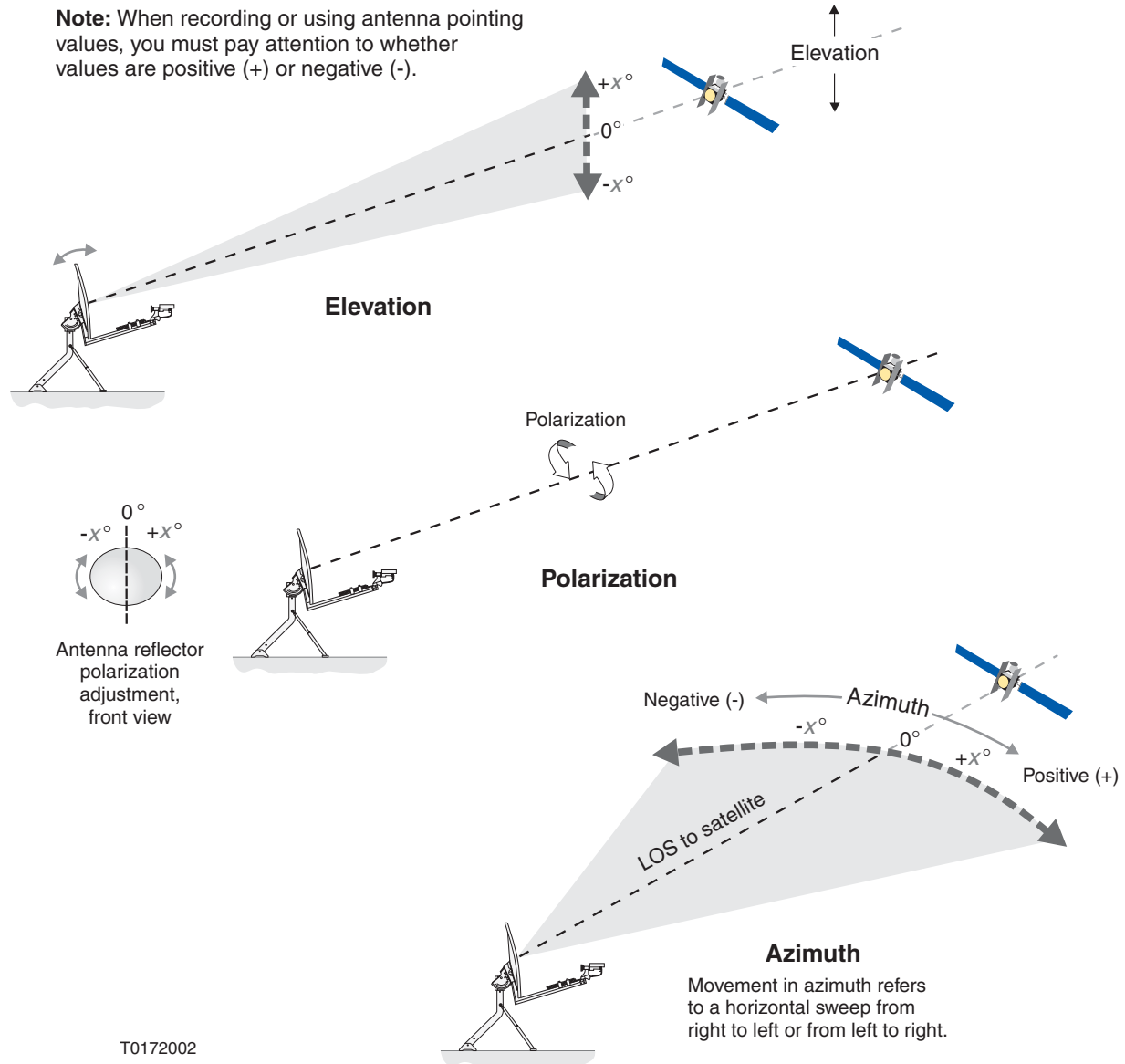

Figure 47: Adjusting elevation, polarization, and azimuth

## Adjustment locations on the antenna

Figure 48 shows the mechanical adjustments for azimuth, elevation, and polarization. All pointing adjustments require a ½-inch wrench.

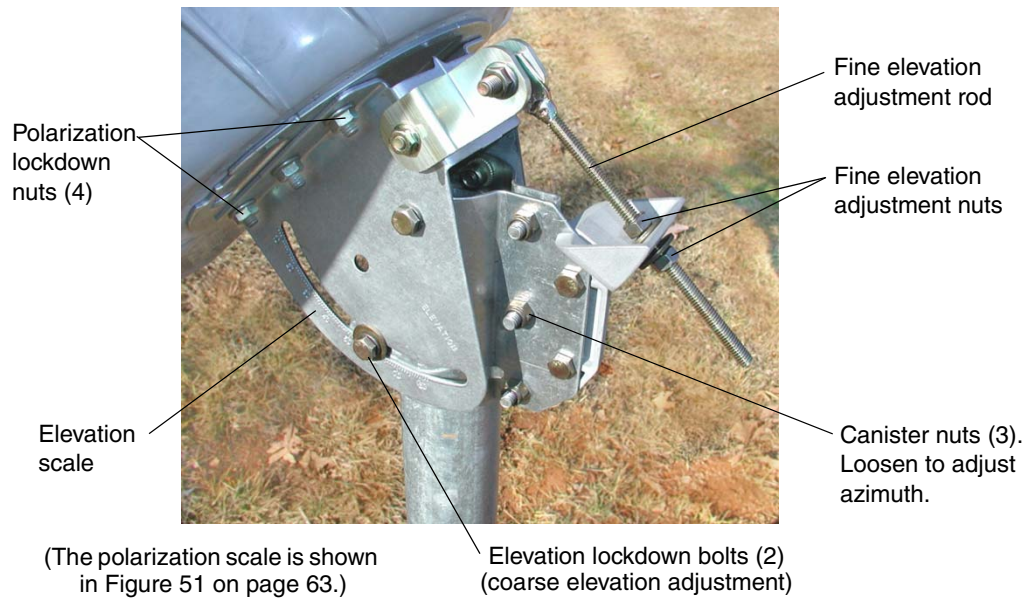

Figure 48: Pointing adjustments on the antenna—elevation, polarization, and azimuth



Note: The elevation lockdown hardware shown in Figure 48 may be two nuts or two bolts (one on each side of the Az/El assembly).

Detailed procedures for adjusting the antenna are included in the sections that follow. As you make pointing adjustments, tighten the lockdown nuts or bolts enough to prevent movement of the antenna reflector. When you are done pointing, you fully tighten all lockdown nuts and bolts.

## Setting coarse elevation

*The antenna pointing procedure begins with the steps described in this section and continues through the end of this chapter. Follow the instructions in the order they are presented.*

Set the initial (coarse) antenna elevation to the initial elevation value given by the installation software, as follows:

1. Loosen the two fine elevation adjustment nuts indicated in Figure 49 so the antenna reflector can move forward and backward.
2. Loosen the two elevation lockdown bolts indicated in Figure 49, a little at a time, until you can rotate the antenna reflector forward and backward to adjust the elevation.



Note: Do not tighten the elevation lockdown bolts yet because you will be adjusting elevation further, as explained in *Fine elevation adjustment* on page 62.

3. Set the elevation to the value given by the installation software.

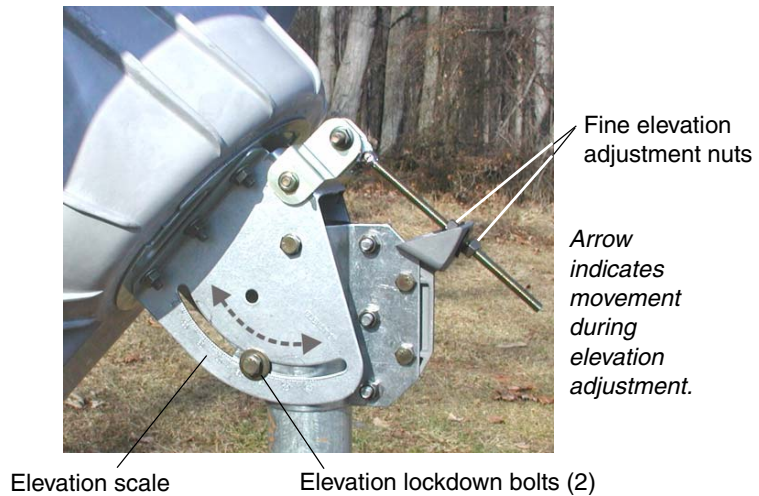

Figure 49: Setting coarse elevation

---

## Fine elevation adjustment

The fine elevation adjustment rod (shown in Figure 50) allows you to make fine adjustments of the antenna elevation. Where subsequent instructions call for fine adjustment of the antenna elevation, fine-tune the elevation setting as follows:

1. Make sure the two elevation lockdown bolts are loose enough to allow the reflector to move as indicated by the arrow in Figure 50.
2. While watching the signal strength display, adjust the fine elevation adjustment nuts (Figure 50) to achieve maximum signal strength:
  - a. Move the top nut to allow movement, then make adjustments with the bottom nut.
  - b. Adjust by turning the bottom nut a few turns clockwise and counterclockwise, until you peak the signal.

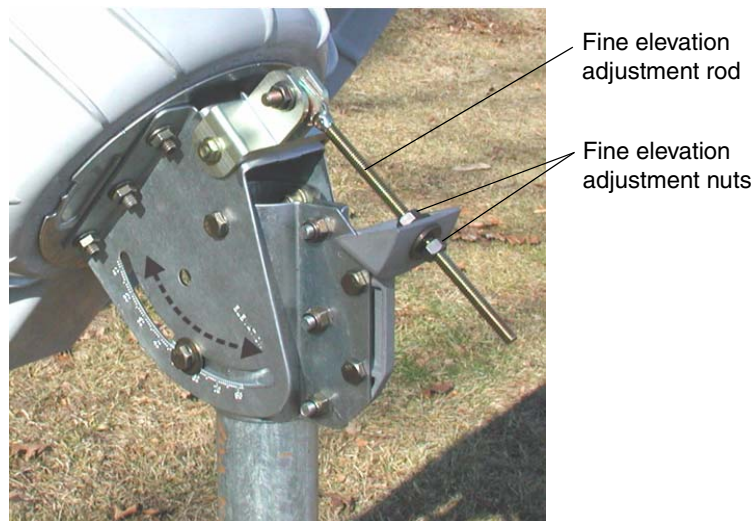

Figure 50: Fine elevation adjustment

3. When the signal is peaked, tighten the two elevation lockdown bolts.

---

## Receive pointing

Receive pointing peaks the receive signal. You must peak the signal even if the antenna is locked to it.

You use the installation software to check the signal strength. Then you adjust the antenna to peak the signal. The installation software shows numerical and graphic indications of signal strength. Detailed instructions for these procedures are given in the following sections.



**Initial elevation setting** Make sure the antenna reflector is set to the initial elevation value given by the installation software.

**Setting polarization** *Polarization* refers to rotation of the antenna (as shown in Figure 47 on page 59) and is measured in degrees from zero (no rotation), positive or negative. Polarization is positive east of the satellite longitude and negative west of the satellite longitude.

For an antenna with a J-type radio, you adjust polarization on the antenna only. For an antenna with a cradle-type radio, you set polarization on the antenna to 0° and then set polarization on the radio. If you are installing the antenna with a cradle-type radio, see *Setting polarization for the cradle-type radio* on page 47. (You will also use the instructions in this section.)

Set the antenna (reflector) polarization as follows:

1. Loosen the four polarization lockdown nuts just enough so you can rotate the antenna reflector. See Figure 51. Do not adjust the center nut on each side, as noted in Figure 51.
2. Rotate the antenna to the desired polarization value as indicated by the polarization scale (shown in Figure 51).

*J-type radio:* Set the antenna polarization to the initial polarization value given by the installation software.

*Cradle-type radio:* Set the antenna polarization to 0°; then see *Setting polarization for the cradle-type radio* on page 47.

Arrow indicates movement during polarization adjustment.

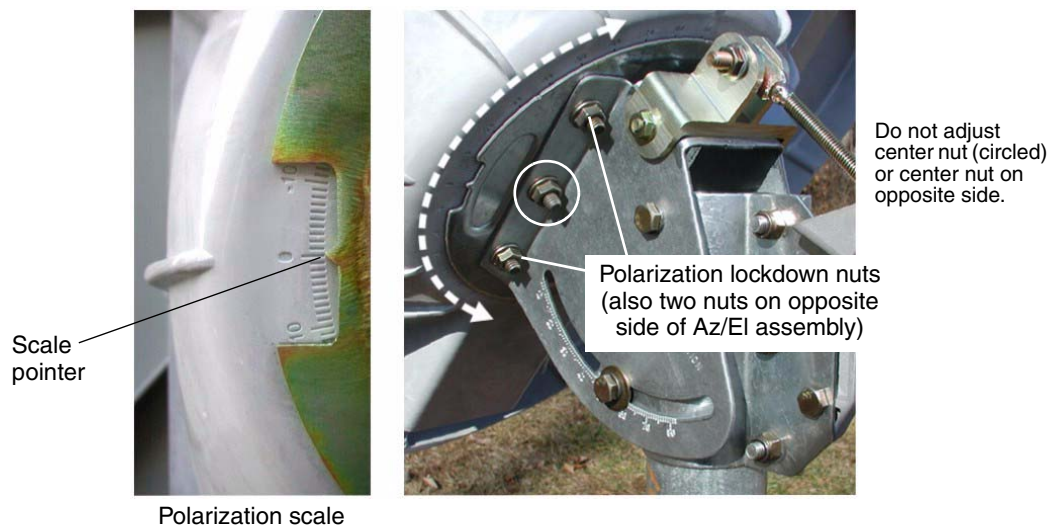

Figure 51: Polarization adjustment on the antenna

**Setting azimuth** With the elevation and polarization set to the initial values given by the installation software, follow these steps to set the antenna azimuth to the initial value specified by the installation software and then adjust it as necessary:

1. Use a compass to determine the azimuth bearing specified by the installation software.
2. Prepare to make azimuth adjustments as follows:
  - a. Fully loosen the three canister nuts shown in Figure 52.
  - b. Tighten the top nut only, just enough so you *cannot* rotate the Az/EI assembly around the mast.
  - c. Loosen the top nut incrementally until you can rotate the Az/EI assembly by holding and moving it.

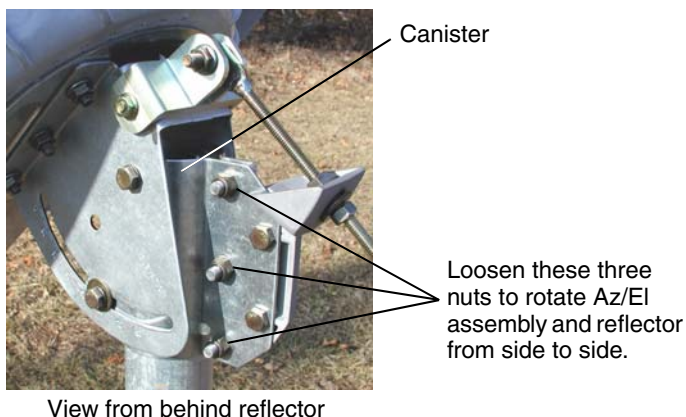

Figure 52: Azimuth adjustments on the antenna

3. *Stand behind the antenna*, grasp the antenna reflector bracket (not the reflector), and rotate the antenna assembly about the mast until the reflector is pointed in the approximate azimuth heading.
4. Adjust the azimuth to the right about  $\frac{1}{8}$  inch.
5. Let go of the reflector bracket and count slowly to 5 while reading the signal strength value from the OPI or computer. You must allow the IDU enough time to track and register the signal strength.



Note: Make small adjustments (not more than  $\frac{1}{8}$  inch of azimuth as measured at the mast). Wait 5 sec between adjustments to give the IDU enough time to lock onto the satellite signal.

6. After acquiring a signal, adjust the azimuth to obtain the highest signal quality.
7. Go to *Peaking the signal (procedure)* on page 66 and follow the instructions there.

***If you cannot detect a signal*** Follow the steps in this section (steps 1 through 3 and/or steps 1 through 6) *only if you cannot detect a signal*.

*If no signal is present:*

1. Repeat steps 3 through 5 in *Setting azimuth* on page 64. (Adjust the reflector to about  $\frac{1}{8}$  inch to the right of the approximate azimuth.)
2. Keep moving the antenna reflector to the right a little at a time until you detect a signal.
3. If there is no signal, sweep back  $\frac{1}{8}$  inch at a time to the left until you detect a signal.

*If you still cannot detect a signal*, there may be an error. *If there is no signal*, perform the following quick checks.

1. Check the coaxial cable connections at the LNB, IDU, and all the connections in between.
2. Make sure there are no obstructions such as trees blocking the signal.
3. Make sure you recorded and properly set the azimuth, elevation, and polarization values.
4. Verify the azimuth setting by moving 15 ft in front of or behind the antenna and taking another compass reading. Metal near the compass, such as a car or even a belt buckle, can give a false reading.
5. Point the front of the antenna reflector to the left of the estimated bearing.
6. Go back to step 3 in *Setting azimuth* on page 64 and try again.

When you have acquired a signal and adjusted azimuth to obtain the highest signal quality, go to *Peaking the signal (procedure)* on page 66 and follow the instructions there.

**Peaking the signal (procedure)** After the satellite signal is detected, peak the signal as follows:

1. Mark the mast with a pencil so you can find the azimuth bearing again.
2. After detecting the satellite, continue turning the antenna reflector a small amount in the same direction you were turning it when you began receiving the satellite signal. Pause for 5 sec after each time you move the reflector.
3. Turn the reflector in this fashion until the signal strength values displayed by the installation software begin to decrease.
4. When the numbers begin to decrease, slowly turn the reflector in the opposite direction until you regain the highest number that was previously achieved.  
(Achieving this maximum signal strength is called *peaking the signal*.)  
Make a note of the peaked signal strength for reference as you complete the pointing process.
5. When you have peaked the azimuth, snug down the three canister nuts as follows:
  - a. Alternately and incrementally tighten the lower two nuts until the flanges makes contact.
  - b. Snug the top nut.
6. Fine tune the elevation adjustment to verify that signal strength remains at the highest level.
7. If necessary, fine tune the adjustments for azimuth, elevation, and polarization to make sure you have achieved and maintained the highest possible signal strength.
8. Erase all marks previously made on the mast.
9. Lock down (fully tighten) all adjustment nuts.

---

## Isolating the transmit signal

To prevent signal cross talk, you use a procedure known as Automated Cross Polarization (ACP) to isolate the transmit signal from the receive signal. ACP test functions are included in the installation software.

The ACP software operates in two different modes—manual or automatic. Manual mode gives real-time feedback of cross polarization isolation measurements while you adjust the antenna. Automatic mode takes a snapshot of the cross polarization isolation measurement.

ACP fine pointing consists of testing using both the manual and automatic modes and adjusting the antenna by small increments (if necessary) until it passes both the manual and automatic ACP tests.

Follow the general instructions below for the ACP tests. Use the installation software screens to initiate tests and see the test results.

### **Manual ACP test** First run a manual ACP test:

1. Lock down all antenna adjustment nuts and bolts.
2. Initiate the manual ACP test by selecting the manual cross polarization test type.

*If the manual ACP test passes, stop the test and proceed to Automatic ACP test on page 68.*

*If the manual ACP test fails, let the test continue and follow these steps:*

1. Make small, 1° or less changes in polarization while observing the transmitter isolation.
2. Peak the polarization to the highest possible transmitter isolation.
3. Tighten the polarization lockdown nuts.
4. Check the signal strength.

*When the manual ACP test passes, stop the test and proceed to Automatic ACP test.*

**Automatic ACP test** Verify that the signal is still peaked by initiating an automatic ACP test. To initiate this test, select the automatic cross polarization test type. If the antenna passes the automatic ACP test *and* maintains signal strength within 3 points on the signal strength scale, it is pointed and ready to be registered.

*If the antenna fails the automatic ACP test, follow these steps:*

1. Initiate a manual ACP test.
2. When the test starts, make small, 1° or less changes in polarization while observing the transmitter isolation.
3. Peak the polarization to the highest possible transmitter isolation.
4. Tighten the polarization lockdown nuts.
5. If the antenna passes the manual test, stop the manual test and run the automatic ACP test again.
6. Check the signal strength.

If the antenna passes the automatic ACP test *and* maintains signal strength within 3 points on the signal strength scale, it is pointed and ready to be registered.

*If the antenna passes the automatic ACP test, but the signal strength drops more than 3 points after the test, you must repeat the fine adjustments for azimuth and elevation:*

1. Repeat the fine adjustments for both azimuth and elevation to maximize the signal strength.
2. Repeat the automatic ACP test.
3. Check the signal strength.

If the antenna passes the automatic ACP test *and* maintains signal strength within 3 points on the signal strength scale, it is pointed and ready to be registered.

*If the antenna still does not meet both criteria, repeat very small polarization, azimuth, and elevation adjustments and ACP tests as many times as necessary until you have peaked the signal and the antenna passes the automatic ACP test and signal strength is maintained within 3 points.*

**Important:** When you are finished pointing the antenna, lock down all pointing adjustments. All adjustment points are shown in Figure 48 on page 60.

---

## Final steps

Complete the following steps before leaving the installation site.

**Remove the OPI** Remove the OPI so you can re-use it for subsequent installations:

1. Disconnect the OPI and block, if used.
2. Reconnect the receive cable to the radio.

**Check for safety labels and signs** Make sure the required safety labels and/or signs are present:

- Make sure a *Radiation Hazard Caution* label is present, legible, and visible on the feed arm and on the back of the antenna reflector.
- If the antenna is enclosed by a fence, make sure a *Radiation Hazard Caution* sign is present, legible, and visible on the entrance gate.
- If the antenna is installed on a roof with a permanently mounted access ladder, make sure a *Radiation Hazard Caution* sign is present, legible, and visible on or near the ladder.

**Subsequent steps** The antenna is now installed and pointed, ready for operation.  
To commission the IDU (remote terminal), refer to the IDU installation manual.





# Acronyms and abbreviations

---

## **A**

---

ACP – Automated Cross Polarization

Az/EI – Azimuth and elevation

## **F**

---

FSB – Field service bulletin

ft – Foot

ft-lb – Foot-pound

## **H**

---

hr – Hour

## **I**

---

IDU – Indoor unit

IFL – Interfacility link

inch-lb – Inch-pound

## **L**

---

LNB – Low noise block converter

## **M**

---

mm – Millimeter

## **N**

---

NEC – National Electrical Code

NOC – Network Operations Center

## **O**

---

ODU – Outdoor unit

OPI – Outdoor pointing interface

## **P**

---

P/N – Part number

## **R**

---

RF – Radio frequency

## **S**

---

SBC – Satellite-based commissioning

sec – Second

## **T**

---

TRIA – Transmit/receive isolation assembly

## **W**

---

W – Watt

## **Z**

---

ZIP – Zone Improvement Plan (U.S. Postal Service)



## A

---

- Antenna
  - assembling, general instructions 22
  - illustrated 2
  - kits 8
    - main components 8
    - small hardware parts 18
  - mount 4
  - pointing 56
    - isolating the transmit signal 67
    - mechanical adjustments 60
    - peaking the signal 56, 66
    - prerequisites 57
    - receive pointing 62
  - reflector 11
  - related components 8
  - unpacking 9
- Az/EI and reflector bracket assembly 10, 21
  - installing 23
- Az/EI mount assembly 10
- Azimuth, adjusting 64

## C

---

- Cables 49
  - approved types 5
  - connecting to radio assembly 52
  - maximum length 5
  - receive cable 54
  - routing at the ODU 50
  - service loop 50
  - transmit cable 52
- Connecting
  - cables to the radio assembly 52
  - receive cable 54
  - transmit cable 52
- Connectors 49
  - receive 54
  - transmit 53
- Cradle-type radio assembly
  - described 16
  - installing 43

- polarization
  - calculating 47
  - setting 48

## E

---

- Elevation
  - coarse adjustment 61
  - fine adjustment 62

## F

---

- Feed horn 13
  - installing
    - cradle-type radio 44
    - J-type radio 13, 37
- Feed rods 12
  - installing 27
- Feed support tube 12
  - installing 28
- Final steps 69
- Fine elevation adjustment rod 60
  - using 62

## G

---

- Grounding 4
  - ground screw location 51

## H

---

- Hardware parts list 18

## I

---

- IDU, installing 4
- IFL 5, 49
- Installation site 4
- Installation software 22
  - pointing the antenna 56
- Installation, summary of steps 3
- Installing
  - Az/EI and reflector bracket assembly 23
  - cradle-type radio assembly 43

- feed horn
  - cradle-type radio 44
  - J-type radio 37
- feed support tube 28
- final steps 69
- IDU 4
- J-type radio assembly 31
- OPI 58
- O-ring 37, 45
- radio assembly 39
- reflector 25

Isolating the transmit signal 67

## **J**

---

- J-type radio assembly
  - described 15
  - installing 31
  - mounting brackets 14
  - mounting on feed support tube 39
  - shim kit 32

## **K**

---

Ku-band and Ka-band 2

## **M**

---

- Mast 22
- Mount for antenna 4
- Mounting adapter for radio assembly 14
- Mounting brackets for J-type radio assembly 14
- Mounting, radio assembly
  - cradle-type radio 45
  - J-type radio 39

## **O**

---

- OPI 57
  - purpose 57
  - removing 69
- OPI block 58
- O-ring 45
  - installing 37, 45
- Outdoor pointing interface. *See* OPI

## **P**

---

- Parts list
  - main components 8
  - small hardware parts 18, 19
- Peaking the signal 56, 66
- Pointing values 22
- Pointing. *See* Antenna, pointing
- Polarization
  - adjusting the antenna 63
  - cradle-type radio 47
  - shim for vertical or horizontal transmit polarization 32

## **R**

---

- Radio assembly
  - connecting cables 52
  - cradle-type
    - described 16
    - installing 43
    - mounting on feed support tube 45
    - polarization, calculating 47
    - polarization, setting 48
    - setting polarization 16
  - J-type
    - described 15
    - installing 36
    - mounting bracket
      - lower 39
      - upper 36
    - mounting brackets 14
    - mounting on feed support tube 39
    - shim kit 32
  - mounting adapter 14
  - types 15
    - antenna kits for 8
- Receive cable
  - connecting to the LNB 54
  - routing 51
- Receive pointing 56, 62
- Reflector 11
  - attaching 25

## **S**

---

Safety labels and/or signs 69  
Shim for transmit polarization 32  
Signal strength 62  
    maximizing 66  
Site, installation 4  
Summary of installation steps 3

## **T**

---

Tasks, antenna installation 3  
    related tasks 4  
Tool sizes matched to hardware sizes 20  
Tools needed 20  
Torque 22  
    maximum values 22  
Transmit cable  
    connecting 52  
    routing 50  
Transmit polarization shim 32  
Transmit signal, isolating 67  
Transmitter, connecting 52

## **U**

---

Unpacking the antenna 9

## **V**

---

Vertical shim kit 15, 32

## **W**

---

Waveguide transition 13, 37

